

4 Behind the Scenes at a Broadcasting Station

RADIO BROADCAST

How to Make a Receiving Set That's a "Knock-out"

What Causes Fading?

Eliminating Interference
with a Home-Made
Wave-Trap

Who Will Retail
Radio?

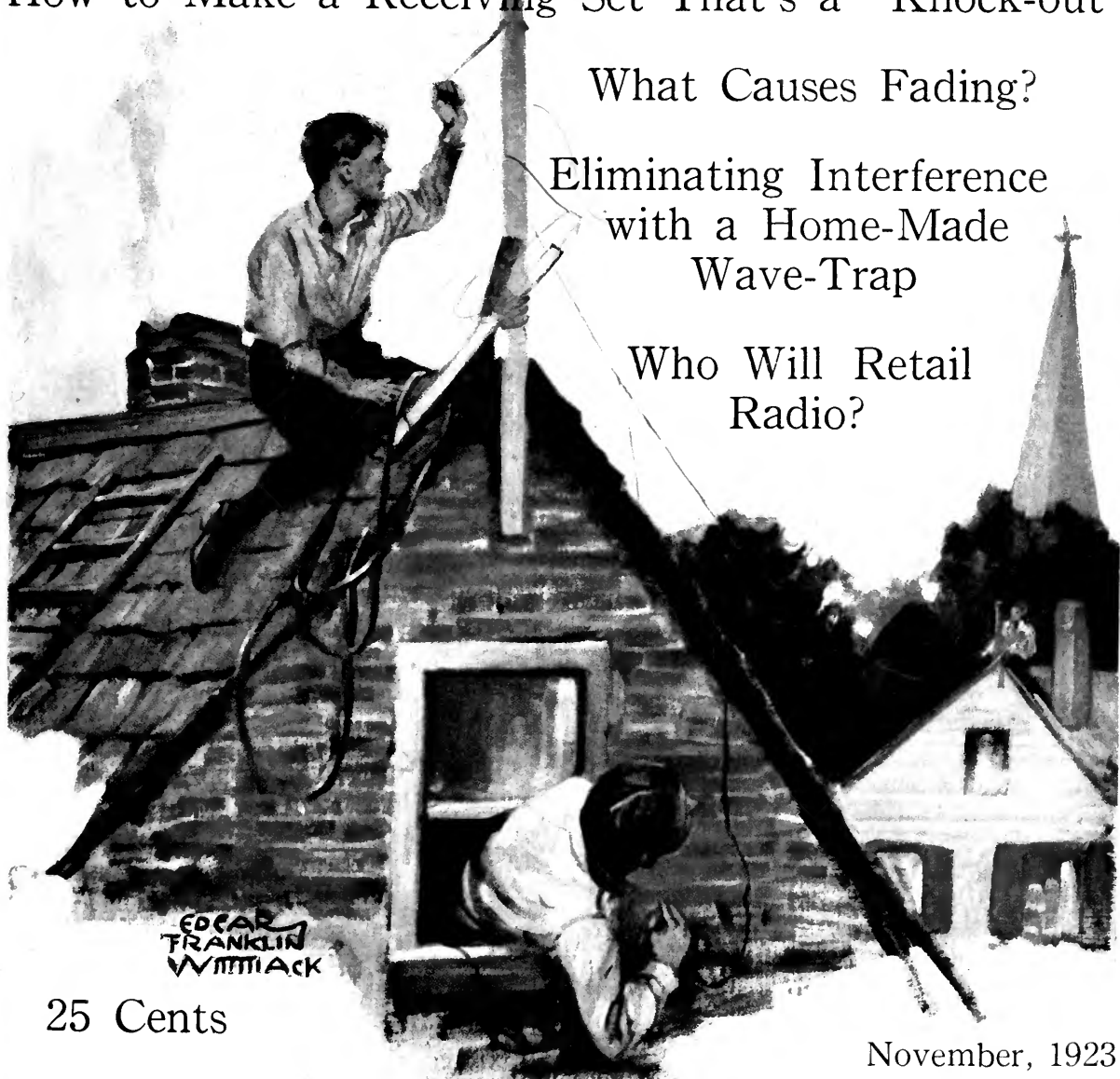

25 Cents

November, 1923

Published by

DOUBLEDAY, PAGE & CO.

Garden City, N. Y.



It Bridges the Vastness of Space

SINCE Marconi first successfully spanned the Atlantic Ocean, with the wireless telegraph, radio has ever been outstanding as an invention of unlimited importance to humanity.

In 1909 the broadcasting of that now famous distress call, CQD, from the sinking passenger liner, S. S. *Republic*, established in the eyes of the entire world the tremendous importance of radio on the high seas.

In 1912, when that gigantic liner, the S. S. *Titanic*, struck an iceberg far from shore, in the north Atlantic, with thousands of passengers aboard, it was the SOS call of her wireless that brought rescue ships from all parts of the ocean. Here again radio demonstrated to the world its great service in the saving of human life.

During the war communication controlled the destinies of armies. Here radio played an exclusive part in the establishing of communication between ships at sea, from ship to shore, and from aeroplane to ground, where the use of wires was impossible.

In recent years the development of the vacuum tube has not only improved radio for the purpose of marine, commercial and military communications, but through radio telephony and public broadcasting, has established a new and even greater service to humanity.

Cunningham Vacuum Tubes are the product of years of research and experimental work by the Engineers of that great scientific organization, the Research Laboratory of the General Electric Company.

Cunningham Tubes are standard for all makes of receiving sets. Each of the numerous types have been designed to operate with maximum efficiency in one or more of the various applications of vacuum tubes to the radio art.

*A Specially
Designed Tube
For Every
Radio Use*

Cunningham Radio Tubes

C-301A—6 Volts ¼ amp. Amplifier	\$6.50
C-299—3 Volts .06 amp. Dry Battery Det. and Amp.	6.50
C-300—6 Volts Gas Con- tent Detector	5.00
C-11—1.1 Volts .25 amp. Dry Battery Det. and Amp. Special Base.	6.50
C-12—Similar to C-11 with standard base.	6.50

Patent Notice: *Cunningham tubes are covered by patents dated 11-7-05, 1-15-07, 2-18-08, and others issued and pending. Licensed for amateur, experimental and entertainment use in radio communication. Any other use will be an infringement.*



E. J. Cunningham Inc.

Home Office:
248 First Street
San Francisco, Calif.

154 West Lake Street
Chicago, Illinois

30 Church Street
New York City, N. Y.

★ Tested and approved by RADIO BROADCAST ★

MAY 2 1924

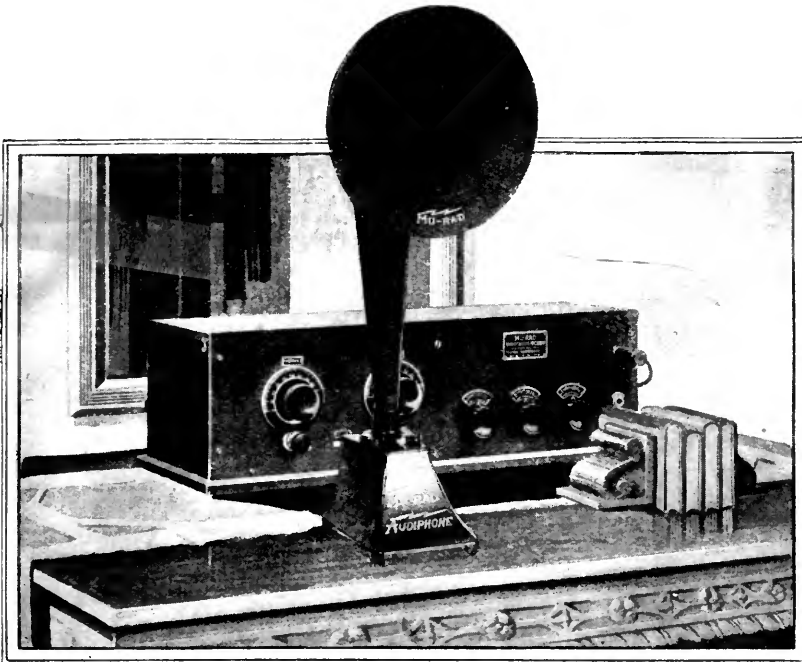

A New MU-RAD Accomplishment —
The MU-RAD AUDIPHONE

The super-sensitive mica diaphragm produces sound by the contraction and expansion of an actuating contact, just as the vocal cords produce the voice.

No Extra Battery Connections

PRICE
\$25

THE REVOLUTION, wrought in radio reception by the MU-RAD RECEIVER is equalled by this radical improvement of sound amplification. The *MU-RAD AUDIPHONE* aimed for a higher perfection than ever attempted — duplication in electro-mechanical form of the greatest sound producing organ, the human voice. The result of five years' continuous research is a radio reproducer worthy of a finer classification than "loud speaker"; it is *a new radio instrument!*

WRITE FOR LITERATURE AND THE NAME OF THE NEAREST MU-RAD DEALER DEMONSTRATING THE MU-RAD AUDIPHONE

MU-RAD LABORATORIES, INC. ★

803 FIFTH AVE. ASBURY PARK, NEW JERSEY

★ Tested and approved by RADIO BROADCAST ★

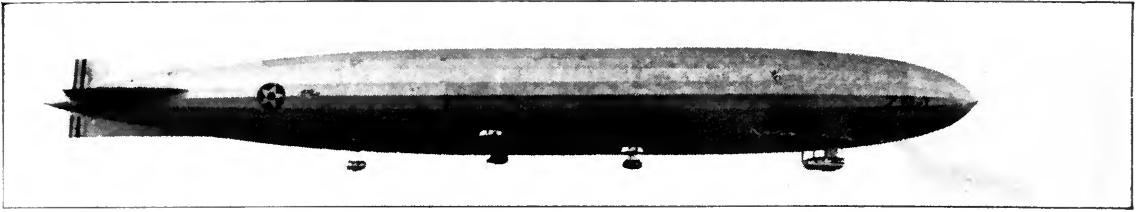

THE ZR-1 AS SHE APPEARED ON HER MAIDEN VOYAGE

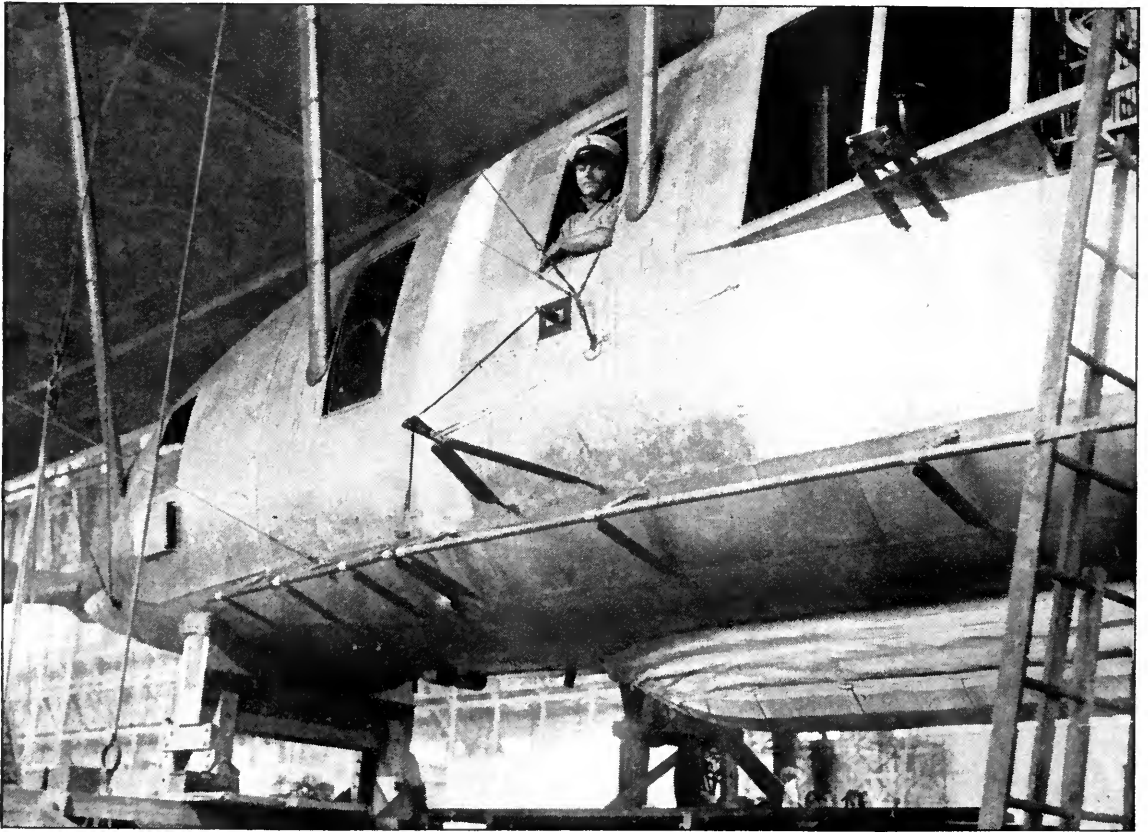

THE RADIO SHACK ABOARD UNCLE SAM'S LARGEST DIRIGIBLE

The ZR-1, recently completed at Lakehurst, N. J., is equipped with a 3-kilowatt continuous-wave transmitter and a Navy type receiver. The aerial consists of about one hundred feet of wire, weighted at the end, which is paid out through the side of the gondola. John T. Robertson, radio operator on the ZR-1, is shown at the window of the operating room. During the first flight, he kept the station at the Lakehurst field in constant touch with the ship's manoeuvres

RADIO BROADCAST

Vol. 4 No. 1



November, 1923

The March of Radio

RUSHING RELIEF TO JAPAN

IN ABOUT three minutes at noontime on September first, two of the largest cities in the world, and towns for several hundred miles along the eastern coast of Japan, were transformed from thriving communities into masses of flaming wreckage strewn with dead and injured. Thousands of people who were trapped in buildings crashed to destruction; other thousands were buried beneath the ruins that fell without warning upon them. Some jumped into the canals, where they were killed by falling débris, or drowned. Eyewitnesses reported that they looked "like fishes floating on the surface of a pond."

Communication systems were destroyed. The radio transmitting station at Haranomachi, 155 miles from Tokio, was the first means by which news of the catastrophe and appeals for first aid could be sent to the outside world. For several days the brief dispatches, often conflicting but always horrible in their accounts of the loss of lives and the crying need of relief, contained only the barest outline of the situation. What news there was, had to be delivered by a courier system, hastily established between the stricken area and Tomioka, 187 miles from Tokio, where is located both the remote control apparatus for the 500-KW arc transmitter at Haranomachi, and the trans-Pacific receiving station.

K. Yonemura, superintendent of the Japanese operating staff, sent the first message. It was received by the Radio Corporation station in San Francisco, and read: "Conflagration

subsequent to severe earthquake at Yokohama at noon to-day whole city practically ablaze with numerous casualties all traffic stopped."

This despatch was given immediately to the Associated, International, and United Press; newspapers throughout America had headlines across the tops of their front pages the next morning; President Coolidge appealed to the American people for immediate and liberal contributions to the Relief Fund; and the great Red Cross organization, almost overnight, started its relief ships speeding for Japan from the nearest supply bases and organized country-wide drives for money with which to carry on the work.

During the following days, bits of news, rushed to station JAA at Tomioka, were translated into English by Yonemura and his assistants and sent out across the sea. Transmitting and receiving was carried on without a hitch at top speed. Although many of the land lines in the destroyed area remained intact, the central telegraph buildings were reduced to a mess of ruins and tangled wires, so that no messages could be sent to the radio station through these channels. But while successive shocks were wreaking further havoc in Tokio and Yokohama, while fires were breaking out in fifty different places simultaneously, while landslides were carrying whole thickly populated districts into the sea, and tidal waves were destroying ships and villages, communication between Japan and San Francisco—4,600 miles away—was still maintained.



THE MAN WHO KEPT THE MESSAGES MOVING
K. Yonemura, operating superintendent at the Japanese radio station who maintained communications with the outside world during the period of the earthquake

All of which indicates something of the part played by radio in one of the greatest catastrophes in history. The number of lives which radio has been responsible for saving in stricken Japan can never be closely estimated. If the 660-foot steel-and-concrete tower which supports the transmitting aerials at JAA had been brought down by the earthquake, thousands who have now been saved would surely have perished. As in the case of accidents at sea, it is in the sudden emergency—when seconds mean lives and when there is no other means of communication—that radio performs its finest service.

Let Your Discarded Set Serve Those Who Served You

ONLY a few short years ago American hearts were thrilled by martial music and the sound of marching feet. We looked with confidence and approbation on the flower of our nation, as in every countryside, town and city, it passed in review prior to its departure for Europe and the great adventure.

War was our business for the time being, and we went into it with a will. Drives for this, that, and the other thing were put over by our relief organizations and our leading citizens. "Give till it hurts!" was our slogan, and as a nation, we responded.

Following the Armistice, our ports were the scenes of much rejoicing. "The boys" were coming home. Upon the arrival of each vessel whistles blew; bells rang; and once again the marching and the music quickened our pulses and stirred our hearts with feelings of mingled joy and sadness, for there were many blank files in the ranks. Of those who returned, many had to be brought on hospital ships—their marching days were over. Warm-hearted, impulsive Americans were eager to entertain these battered returning soldiers or sailors, and the sincerity of their welcome helped not a little to nerve the boys for the business of "carrying on." Thanksgiving Day and Christmas and New Year's were happy days for most of our war-worn veterans. Despite their infirmities, life still held something for them, for here, at home, were tender women and generous men solicitous for their comfort, and Uncle Sam himself was doing his level best to make them happy.

Now, after the passing of several summers and winters, the war, except for the income tax, the prohibition laws, and other occasional reminders, is a thing of the past—is like a great movie film, captivating in its glamor, its tragedy, and its departure from the routine of peace, but finally put aside with other memories. By degrees we have lost contact with our soldier sick, and the visitor in their hospitals to-day is the exception rather than the rule. Many of those heroes who helped break the Hindenburg Line, who faced death under the sea and in the air, are in hospitals to-day—nearly five years after the Armistice. Their diversions are few, and they have plenty of time to think about their ailments, to say nothing of the heart-aches brought home to them by a fickle and forgetful nation.

Radio is one of the means used during the war to aid in bringing about destruction. At present, several of the greatest advances in the art which came with the war have been incorporated in radio telephony—one of the principal sources of entertainment and instruction in our country. Broadcasting is more personal and more powerful, and to many appeals more strongly than the printed word. Through radio, we have an opportunity to show, in a small way, our appreciation of the valor and staunchness of those who gave more than their lives that we might continue the pursuit of happiness. Many a listener-in has purchased a broadcast receiver and then out-

grown it and used a more powerful set. Would it not be worth while to turn over all receivers of this kind to those men who, following the flag, have been temporarily put out of the running?

Why not get in touch with your nearest Veterans' Hospital or American Legion Post and let it know that you have a set available for use in the hospital? Or, if you prefer, just pack your outfit in a substantial box and send it to RADIO BROADCAST. If you have no preference regarding its disposal, we shall be glad to see that it gets into the hands of some veteran, who, with his buddies, will appreciate it.

WGY Offers \$500 for Prize Radio Drama

WGY, at Schenectady, N. Y., is offering a prize of \$500 for the best radio drama submitted in competition during the three months' period beginning September 1.

The prize-winning play will be presented by the WGY Players during the winter months when transmission conditions are at their best

and when the maximum number of people will be listening-in. The audience is expected to be equivalent in size to the attendance at 500 performances of a stage production in a theatre seating 2,000 people. In addition to the \$500 prize, the successful writer will receive an introduction to a public as large as the reader-circulation of a national magazine, and he will have the personal satisfaction of taking a leading part in the development of a new phase of dramatic art.— Other plays offered in competition will be put on the air if found suitable, and the author will be remunerated in every case.

One year's production of the radio drama by the WGY Players has convinced Martin P. Rice, director of broadcasting for the General Electric company, that there is a public demand for this type of entertainment and that the peculiar requirements of the radio drama as compared with the stage and the screen production will in time result in a new form of dramatic art. The screen has evolved a distinct type of drama which depends solely on the eye to satisfy the imagination. It is for the purpose of stimulating and encouraging the

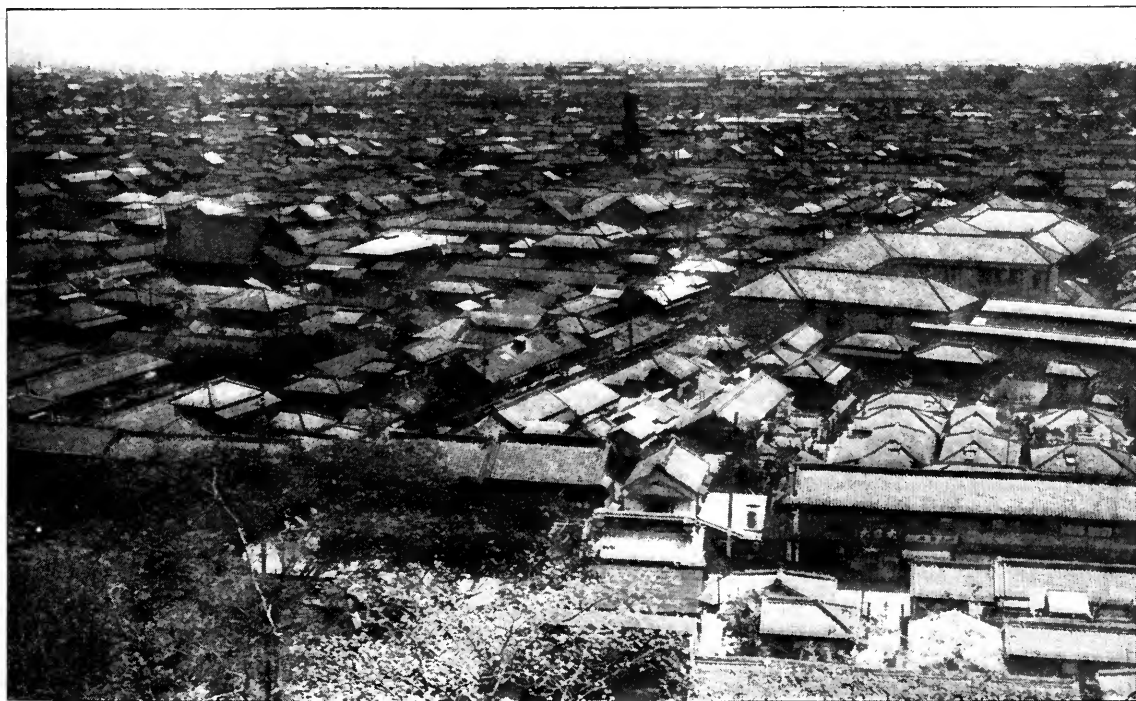

TOKIO, IN WHOSE NARROW STREETS AND CROWDED BUILDINGS THOUSANDS PERISHED

Within a few hours after the first quake occurred, ships summoned by radio were speeding with supplies and food to the scene of the catastrophe. Tokio is in area one of the largest cities in the world, covering some $37\frac{1}{2}$ square miles. A glance at the picture enables one to understand how thousands of terror-stricken people who escaped death or injury from falling buildings were trapped by fires when they tried to flee to safety through smoke and ruins along narrow streets that often ended in blind alleys

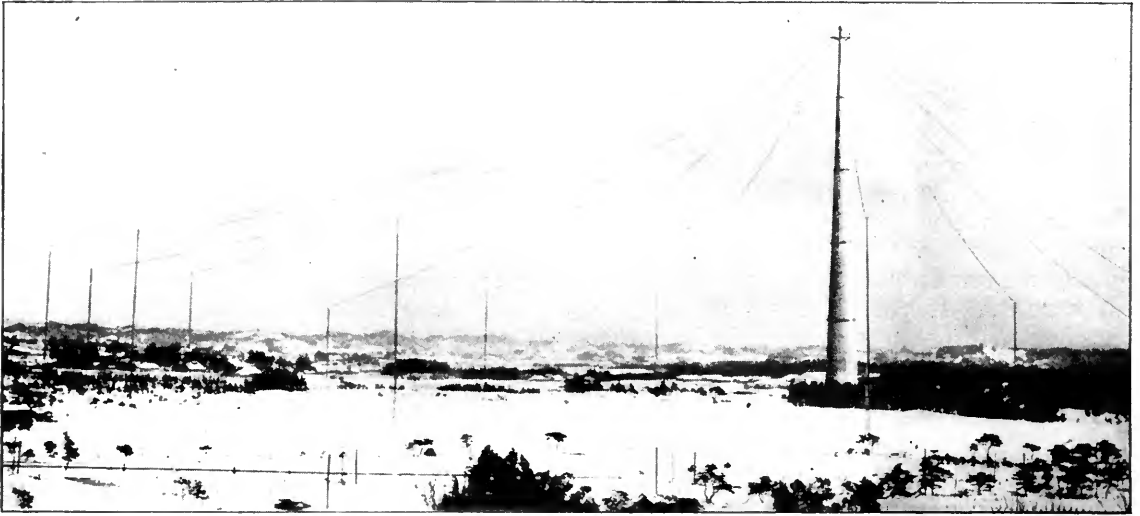

JAPAN'S ONLY IMMEDIATE MEANS OF COMMUNICATION WITH THE OUTSIDE WORLD

This station, JAA, was erected in 1921. It is hard to appreciate from the photograph the size of the reinforced concrete mast. Its top is 660 feet above the ground, and the diameter of its base is sixty feet. A 500-kilowatt arc set is used, on a wavelength of 14,350 meters. Messages bearing news of the catastrophe and requests for aid were sent from this station via the land lines controlled at the receiving station at Tomioka

development of the radio drama that the General Electric Company inaugurates this prize competition.

The author of the radio drama must place himself in the position of writing for a blind man. The lines of the characters must convey a picture of the scene in which the action takes place. This apparent handicap becomes an aid to action, however, as the writer need not restrict his play to three, four, or five scenes. For example, he can depict an automobile race and carry his audience through its exciting phases by means of the lines. He may take his listener from room to room or floor to floor in a dwelling, if farce or melodrama call for such action. The chase, long a popular feature in the early motion pictures, may be brought into the radio play by means of speech. The radio drama requires no scenery. No careful search need be made for locations. The spoken word builds the scenery.

Dramatic situations may be built up by the speaking voice and through the medium of sound making devices. The writer is encouraged to make use of sound devices, and the engineer will provide a means of producing through the air a counterpart of the prescribed sound. Rain, thunder, surf, the roar of a moving train, a pistol shot, an airplane, telegraph key, or automobile motor may all be reproduced in sound to impart atmosphere and realism.

Those who have written short stories, books

of fiction, scenarios, or plays, successfully or unsuccessfully, may have the germ of a prize-winning radio drama. Those interested may obtain a folder which sets forth the rules of the competition, with an outline of the special requirements of the radio play, by addressing Prize Competition, WGY Broadcasting Station, General Electric Company, Schenectady, N. Y.

Broadcasting and the Library

BECAUSE, to a certain extent, the libraries and radio broadcasting have the same aims, it is surprising that they have not coöperated nearly as fully as they might. Much of the radio broadcasting is instructive and entertaining; and so it is with the books on the library shelves. Radio is ever improving the musical and literary tastes of thousands of listeners-in, who, having their interest aroused, may find increased pleasure from music or literature—and the libraries can supply the latter.

One of the most important duties of a librarian, especially in a small town, is telling stories to children. Many of the bed-time stories sent out by broadcasting stations, however, are insipid, lifeless, and "elocuted" rather than told. Would it not be well to have librarians, who have proven themselves past masters at storytelling, do a little broadcasting?

Then, too, in many towns the library is a

community center and it would be possible, under capable advice, to install a receiving set and loud-speaker in order that the townsfolk could listen-in on important speeches or other events broadcasted from cities within range.

Is it because our noses are so close to our own picture that we fail to get the proper perspective of the other fellow's? Surely the library has something to offer us in the matter of stimulating a greater interest in this fascinating science of ours—a science that any of us may enjoy without being scientific, for it is as easy to get results from a modern radio receiver as it is from such a commonplace article as the sewing machine.

Some libraries—usually those in which the librarian has become a "radio bug"—have taken advantage of radio. The recent convention of the New York Library Association, at which a special radio session was held, indicated that there is a great interest on the part of many librarians, who are at a loss to know how best to use the facilities that broadcasting offers. They find a great demand for radio books, but,

being unfamiliar with the subject, do not know what to buy or what to recommend. There are many good books about radio, some general, some specific, and some very, very technical. Each radio enthusiast, whether he is experienced or not, usually has a definite idea about the book he wants; and there are few whose ideas entirely coincide. The New York State Library deals this perplexing situation for the librarian a telling blow by explaining that because radio is such a rapidly progressing art, librarians would do well, at present, to rely upon magazines and pamphlets. Excellent pamphlets may be obtained from the Superintendent of Documents, Washington, D. C.

Statistics are likely to be boresome, but we cannot overlook this opportunity to summarize briefly what radio is doing, and it is hoped the subjects will be looked into further by up-and-doing librarians.

There are four main divisions of radio activity: ship communication, broadcasting, international communication, and amateur communication.

As there is no other method of keeping in touch with vessels at sea, the importance of radio in ship service may be well appreciated. And this means of contact is not confined to the mere exchange of messages; it is an important addition to the mariner's devices for enabling him to navigate properly, whether he is under the sea, on the sea, or in the air. So many descriptions of radio saving life at sea have been published that we feel reiteration is unnecessary.

The newest division of radio is, of course, broadcasting. It is the application of this branch of the science, which in the early days was considered the chief drawback to radio (because secrecy was

impossible), that has of itself commanded a position among the greatest industries we boast. Its importance in moulding nationwide opinions on politics, religion, learning, brotherhood, and even international relations is second only to printing. The day is rapidly approaching when most of our homes will be radio-equipped. Bringing the farmer and the sheep herder and the mountaineer into intimate contact with the world's greatest exponents of culture must help to make a more cultured race. Is not such culture one of the dispensations of the ideal library?

The field of international radio communication is not an entirely new one, as is the case



AUGUSTUS H. SHEARER

Past President of the American Library Association, who is keenly interested in the development of radio for the library and the library for radio. (See Mr. Shearer's statement on page 8)



Photo by Courtesy U. S. Forest Service

WEALTH—

Compare this with the picture on the opposite page. This gives an indication of the vast areas of timber in one section of our Far West—the Columbia National Forest, Washington. Signaling by beacons, flags, heliograph or other visual methods have limitations imposed by conditions of weather, distance, and topography; courier systems are slow, and wire telegraphy impracticable. Radio is the one system by which reliable, rapid communication can be maintained between scouts and fire-fighters

with broadcasting, but it is one that is less spectacular and less intimately associated with our home life and is not accorded the importance it deserves. Few realize that nearly one third of the communication between this country and Europe and nearly half of the traffic across the Pacific is now carried on by radio—incidentally at a rate somewhat below existing cable rates for the same service.

A great network of high-powered stations, now in existence or in process of construction, will link up all the principal countries of the world. The significance of this far-flung system of communication was recently demonstrated before the Institute of Electrical Engineers when a lecturer sent four messages—one each to England, France, Norway, and Germany—and received replies to each in less than five minutes.

To-day, the amateur activity is greater than ever before, although it has been overshadowed to a considerable degree by broadcasting. It is a very worthwhile division of radio, and it is well to remember that many of the inventions that have gone to make radio the industry it is to-day must be credited to amateurs.

The carrying on of communication between individuals by radio has always tended to promote technique in design and operation. In fact, during the World War, many of those

who undertook the task of teaching radio were recruited from the amateur ranks. Amateurs, as a whole, are very much on the job and always willing to lend a hand, and they have a better knowledge of the workings of radio than many of the so-called experts, whose principal stock in trade is a glib tongue. Where the librarian can secure the cooperation of a live amateur there is little doubt about the success of radio in the library.

From the other side of the fence, the librarian has a story to tell, for the library has much to offer the public which most of the public knows little or nothing about. In the words of Mr. Augustus H. Shearer, past President of the American Library Association;

The position of the library with regard to radio must be considered very soon and with great care. Already it has been discussed at the American Library Association and at the New York State meetings. The recent drop in circulation of books may be caused by interest in radio. But the library doubtless has a place in the broadcasting program. This was brought up first by a Western library which broadcasted the main points of new government documents. New books, book-reviews, and children's stories for bedtime have all been proposed as fields for the librarian, and there is no doubt that the librarian expert in various lines, would be glad to serve in these ways. The other side of the relationship,

that is, receiving by the library, is still a question. Where libraries have suitable auditoriums, it is possible that the library's function should be broadened to provide for its clientele the things which the books can not give—the spoken word and music. This is one of the effects that radio may have on existing institutions, and the library must be alive to its possibilities.

Protecting Our Wealth in Timber

OF ALL the waste to which much of our national wealth is subjected, probably the greatest occurs in our timber lands. There is undoubtedly a greater loss each year in this one natural source of wealth than the total capital tied up in all the radio apparatus in the world. Of course the part of this waste which is caused by inefficient lumbering methods is gradually being eliminated as the price of lumber and its by-products continually mounts. But another and greater waste is a result of the tremendous

forest fires which occur generally as the woods dry out in the latter part of the summer, making the underbrush dangerously combustible, and ready for the locomotive's spark or some camper's carelessly tended fire.

Not only is there an enormous direct loss of the timber and the destruction of the young trees without which new forests cannot be created, but, indirectly, due to consequent floods and crop failures, forest fires levy a heavy tax which might be greatly reduced by modern communication methods.

Those who have not been in mountain territories devastated by a recent forest fire may not appreciate to what an extent the ground itself is consumed by the fire. In many forests the earth in which the trees grow is itself nothing but decayed and decaying vegetation—leaves, needles, and rotting tree trunks. When the material is dried out, it burns just like peat, so that many times the country over which a fire has passed is left nothing but bare rock.



Photo by Courtesy U. S. Forest Service

—AND POVERTY

The fire which wiped out this area in the Colorado National Forest is shown still smouldering. It might have been checked in its early stages had the radio telephone or telegraph given the fire-fighters immediate information of it. The destroyed timber in a fire such as this is not the only loss. The ground, composed largely of decayed leaves and trees, is dried out and burns like peat, with the result that on mountain-sides or wherever the land is sloping, heavy rains race down into the valleys, causing floods, as there is no longer the spongy earth to hold the water. If crops survive these floods, they are likely to perish in the dry season, none of the year's rainfall having been held in reserve in the timber land.



Photo by Courtesy U. S. Forest Service

RADIO TELEPHONE APPARATUS READY FOR A TRIP ACROSS THE MOUNTAINS

Portable equipment is used by the forest rangers in the Missoula National Forest, Montana, for communication over short distances which cannot practicably be spanned in any other way

When rain falls in such districts it must immediately run off. The thick layer of humus—which has served for centuries as a sponge to hold the water for long periods, letting it out in the form of springs and rivulets throughout the normally dry season—having been consumed, the water runs off as fast as it falls and so causes the floods with which the forest denuded districts are annually visited. And of course when the dry season follows the rains, the crops generally fail as their normal water supply has been cut off.

These wastes from forest fires are so great that the value of any addition to the present methods of fire fighting and fire preventing, even though comparatively small, must be measured in millions of dollars.

Evidently one necessary adjunct to any scheme of fire fighting is rapid communication between the fire scouts and groups of fire fighters. Evidently, also, the method of communication must be one which permits a rapid transfer of the center of communication from one point to another as the fire races from place to place. The stringing of temporary wires for ordinary telephone connection is difficult if not impossible, and to any one familiar with the operations of the Signal Corps during the recent war the adaptability of radio to the purpose is at once apparent. Communication may be necessary between groups fighting on

opposite sides of the fire, an exigency to which wire communication is hardly suited. The distances to be covered are generally only a few miles, but the groups trying to get in touch with each other often cannot use visible signaling because of smoke or intervening mountains. These considerations point to radio as the means of communication best suited to the circumstances. The small-size Signal Corps radio telephone sets, good for perhaps twenty-five miles under ordinary conditions, and easily transported on a light truck, or even carried by a few men, as some Signal Corps rookies can well testify, are admirably suited to this need, and there are probably thousands of them lying in storage, waiting for just such an opportunity.

As more and more people become acquainted with the possible uses of radio, its use in fighting forest fires will naturally find wider application. From the U. S. Department of Agriculture we learn that only two permanent radio sets are now being used by the Forest Service in its fire control work on the National Forests. One of these is on Medicine Bow Peak, Medicine Bow National Forest, Wyoming, and the other, which is privately owned, is at Laramie, Wyoming. Let us hope that other forest rangers may soon be using portable radio telephone sets as a valuable adjunct to their present apparatus.

Some Problems in the Broadcasting of Religion

AS WE have seen notice after notice of churches putting in broadcasting apparatus to send out their services to thousands who may be listening on Sunday morning, it has often occurred to us to ask the question: Is this a reasonable and useful rôle for radio to undertake? The first answer is naturally, Yes. What better service than sending the gospel far over the land and sea? The idea is a very attractive and reasonable one, the gospel must go far and wide and there is no method which is so well able to carry out the task as radio.

However, when we come to consider whether or not a broadcasting station should be installed in a certain church, the answer is by no means evident, and the more one hesitates to give the answer the more uncertain does it become. Radio reaches those who want to hear, and those who don't. It becomes apparent that we have not to consider the question, shall radio be utilized for broadcasting religion, but rather, shall radio be used by this particular church for broadcasting the particular form of worship used by this church? Thus put, the question is seen to involve much more than is at first supposed. In any good-sized town there are perhaps ten or twenty

different forms of the Christian religion, sufficiently different so that people pass by one church on their way to another where the form of service appeals to them more strongly.

Now, surely, one form of religion has as much right to the radio channels as has any other; it seems as though the Jew has as much right to his religion by radio if he so wants it as has the Christian; and the Catholic as the Protestant. If the rights of the different forms of religion are going to be preserved for each, it is not at once evident that any one form is entitled to the ether. However, if one church is granted this privilege and the scheme proves so successful that other churches are inclined to put in broadcasting stations, and there are no more available channels on Sunday morning, what is the radio inspector to do? Tell the Roman Catholic and Jew they cannot broadcast as all the facilities are at present taken by the Methodists and Baptists? Evidently such a situation is an impossible one.

How then shall the question be solved? We understand it has been the policy of the Bell system to refuse consistently to sell a radio station for church broadcasting, probably because the above pictured situation was visible to them on the horizon of radio development. The fact that this company, which, in general, has very liberal policies, has been so reticent

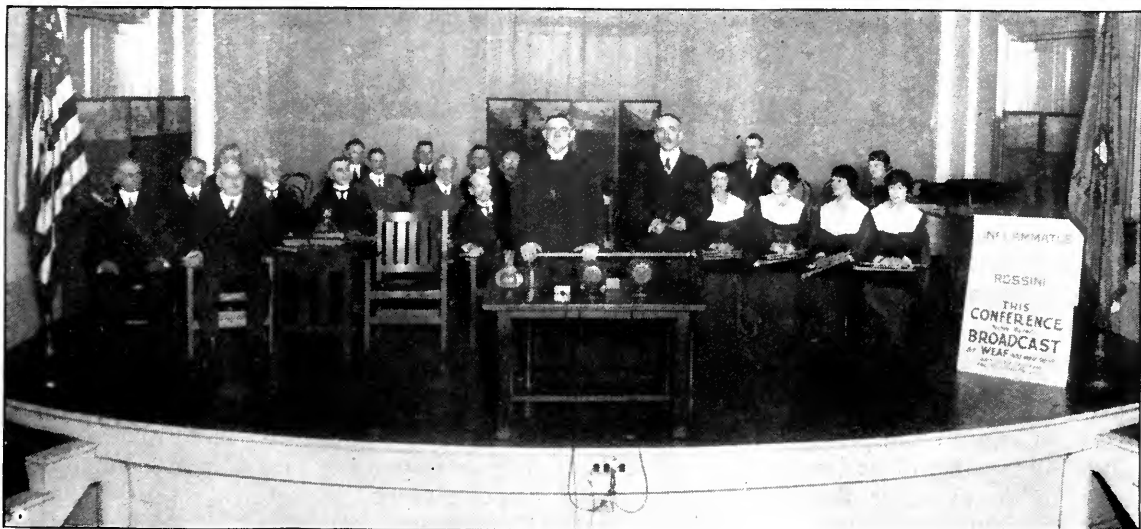

A NON-DENOMINATIONAL RELIGIOUS CONFERENCE OPENED TO THE RADIO AUDIENCE THROUGH WEAF. Rev. S. Parkes Cadman, D.D. (standing at the left) is shown answering questions submitted by the audience at the Men's Conference of the Bedford Branch Y.M.C.A., Brooklyn, N. Y., and read off to him by Mr. Halsey Hammond, conference chairman. The disseminating of religion in this manner has met with a tremendous response from the listeners-in. Filling the ether with the services of any particular denomination, however, is likely to be less justifiable than the broadcasting of these conferences.

about putting broadcasting stations in churches, indicates a real difficulty in the situation.

It is interesting, therefore, to see that, finally, this company, which has the control of broadcasting station installations, has started to broadcast church services, but that it is the services of the New York Federation of churches which are being sent out from WEA. That is, whatever is common to many branches of religion is to be sent over the radio, while those particular ritualistic forms which have an appeal to a comparatively small number, will not be given.

As radio is destined, economically and politically, to bind us together more firmly, can it not accomplish, to some extent at least, unification of the religious ideas of the different creeds and cliques? Will it not do away with the "religious" squabbles which so frequently stir small communities? Is the self-sacrificing and penurious existence of the several ministers in the average small town really necessary? Of course the small town cannot reasonably support the half-dozen ministers which it tries to do, one believing in complete immersion and the other not; one believing dancing should be forbidden and the other holding it a harmless pleasure; one believing in predestination and the other in salvation by belief and deeds. Are these differences, which seem to multiply rather than diminish with passing years, really essential, or rather, have they not been evolved because small groups of people have isolated themselves more and more from other groups and surrounded themselves with a ritual and creed which makes them impervious to outside influences so that a real difference seems to exist where none really is?

It seems to an unbiased observer, viewing these various religious sects from a distance at which details are not visible, that most of the Christian beliefs and creeds are essentially the same. Are there not enough of the essentials, of the real elements of faith, common to all, that a unification might reasonably take place rather than further dissention and separation? Cannot radio perform in this field that knitting together of various peoples which it is sure to do in other fields? Cannot broadcasting supply the essentials of religion so that many fans of nominally different beliefs can listen-in and be benefited? Men with vision believe so, and are working toward that end.

New Threads in the Spider Web

IN A recent communication, General James G. Harbord, President of the Radio Corporation, tells of the inception of the two new radio services which were predicted some months ago. There are now in operation direct radio channels from Radio Central on Long Island, to Holland and to Italy. These long channels will probably not have 100 per cent. reliability, but will be usable during a comparatively large part of the time.

There are now eight different long-distance radio channels emanating from New York, thus constituting a justification for the station name selected by its builders—Radio Central. It does not require much imagination to conceive of New York as the center of a spider web, from which the world's radio channels lead out, and with which all parts of the world are intimately connected by perhaps one or two relays.

In his letter, General Harbord himself brings out the unifying effect expected from radio mentioned above in these columns.

"Direct communication between the United States and Holland, and between the United States and Italy, has long been the dream of our friends across the sea. The opening of this remarkable service will link in a more perfect bond the business and social friendship of these peoples and will assist in bringing about the stabilization of trade conditions which depends so largely upon swift, reliable, and direct communication. . . ."

Music Publishers to Push Their Own Songs at Broadcasting Stations

FRED FISHER, INC., New York music publishers, have announced a new department to be known as the Fred Fisher Radio Department. This department will do nothing but push the Fisher songs at the various broadcasting stations throughout the country.

Mr. Ely Dawson and Victor Oliver, the authors of "M. T. Pocket Blues," are connected with this new enterprise, which marks the first definite step made by any music publisher in creating a special department for such activities. This action is considered by the broadcasting stations as a full recognition of the great publicity value of radio by the music dealers.

J. H. M.

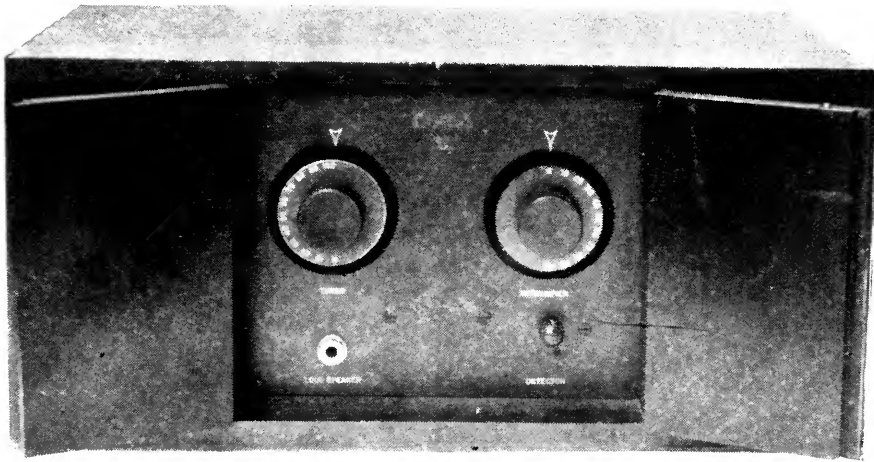

THE COMPLETE OUTFIT

Everything including the A and B batteries may be placed in an attractive cabinet. Some idea of the simplicity of operation may be had from a glance at the panel

How to Make a One-tube Reflex Set That's a "Knock-Out"

Described in a Most Comprehensive Manner, with Complete Instructions for Building and Operating It. It Should Operate a Loud-Speaker over a Crystal Range

By KENNETH HARKNESS

Chief Engineer, The Radio Guild, Inc.

For some time we have been watching for a single-tube receiver combining long range and selectivity with ease of adjustment, economical operation, and portability. The receiver described in this article meets all these requirements in a surprising manner. In our tests we have used it with outdoor and lamp-socket antennas, with a ground connection alone (using no antenna), with every type of receiving tube we could lay hands on—and in every case it delivered the goods. Here is a circuit hard to beat and one we recommend for use by those who have been wanting to build a reliable, single-tube set.—THE EDITOR.

WE HAVE often heard of one-tube receivers that will actuate a loud speaker, but seldom do we have the experience of listening to such a performance; and in radio-hearing is believing—so we are justly skeptical of these "wonder sets."

Indeed, the super-regenerative "flivver" receiver was the first loud-speaking one-tube set* we had occasion to witness in actual operation, and although it made a remarkable showing in reproducing local stations, distant reception appeared impossible and some rather

*See "Operating a Loud Speaker on One Tube Without Batteries" in RADIO BROADCAST for June, 1923.

complicated knob and dial juggling was required in the process of tuning.

Immediately after the "super" craze died down, we were deluged with hashed-up versions of revived and rejuvenated but nevertheless ancient reflex circuits; but until recently we were still looking for a demonstration of a one-tube set that would make a loud speaker "percolate."

For this reason we spent many days and nights in an effort to produce such a single-tube receiver. Our work has resulted in an outfit that is simple and inexpensive to build, easy to install and operate as well as being compact and portable. It will function with any kind of receiving tube now on the market and will

vacuum tube are adjusted to the same frequency, even though they are not in inductive relation, the inter-element capacity of the vacuum tube is large enough to feed back sufficient energy to produce self-oscillation. If a third and independent circuit is closely coupled to either the plate or grid circuit and this independent circuit is tuned, it will cause a reduction in the amplitude of the local oscillations, and if the initial amplitude is *not too great*, the reduction will be effective in preventing self-oscillation. Further, the energy in the independent third circuit may be fed into a rectifying device, the damping effect of which will still further aid in preventing undesirable self-oscillation.

The practical application of this system may be noted in Fig. 1. The primary coil of transformer T₂ is in close inductive relation to the tuned secondary circuit—which latter functions in the dual rôle of the *independent third circuit* and the *tuned detector input*.

The rest of the circuit is standard, but every endeavor has been made to reduce the number

of controls without decreasing efficiency. Thus, the antenna circuit is made slightly aperiodic (i.e., requires no tuning over the range covered by the secondary); the filament circuit is "made" or "broken" by the automatic filament control jack, and a ballast resistance is used in place of an adjustable rheostat; the plate winding of T₂ is sufficient to allow good transformation without direct tuning of the plate circuit; the grid and detector inductances are fairly widely separated and at right angles to each other so there is a minimum of inductive feed-back.

SIMPLE DESIGN AFFORDS EASY CONSTRUCTION

AN AMATEUR should have little difficulty in constructing a receiver of this type as the photographs afford constructional details which may be readily understood, even by the newcomer in the radio game.

In the top view, Fig. 2, the disposition of parts is clearly shown. The transformer mounted behind the left hand condenser constitutes, with the condenser, the tuned an-

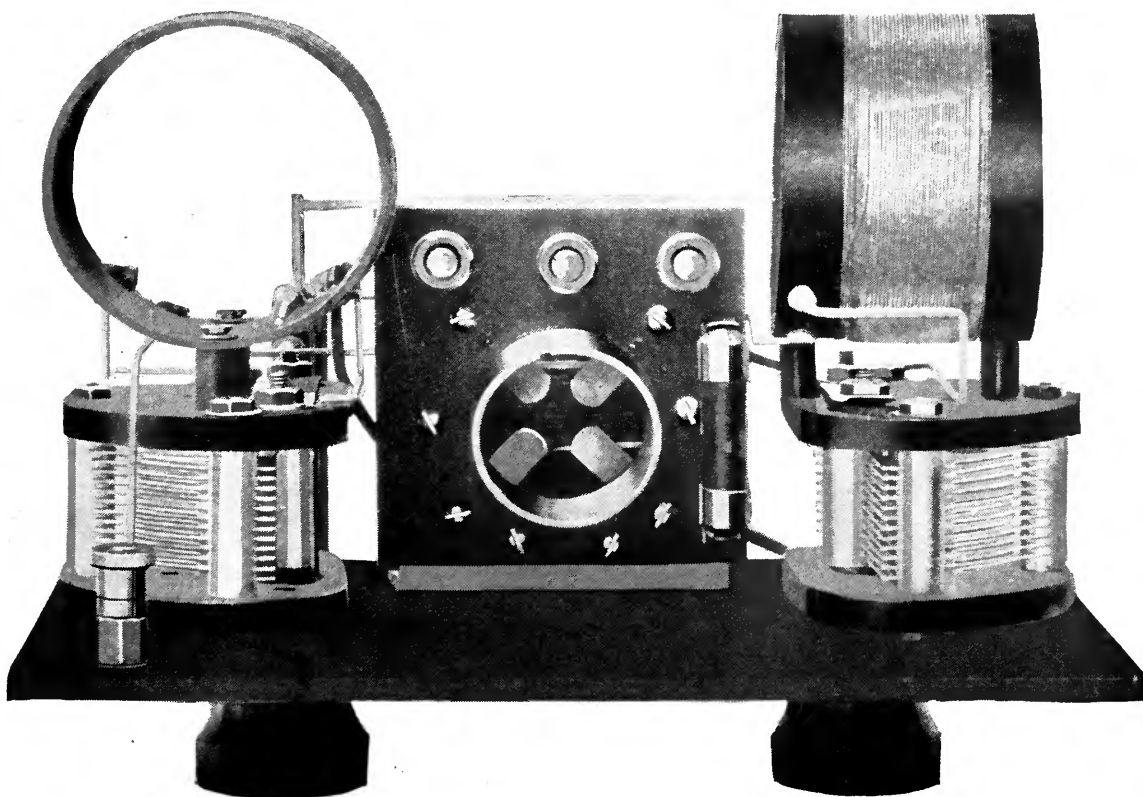

FIG. 2

This is how the receiver looks from above. Note that the two transformers (T₁ at the left, T₂ at the right) are mounted at right angles to each other

tenna, grid, radio-frequency transformer unit T₁; at the right hand side is mounted the plate-detector, audio-frequency transformer unit (T₂).

An "Amperite" or other fixed resistance is mounted at the right side and battery terminals in the rear of the socket strip.

In the front view, on page 13, may be seen the controlling knob of a mechanical crystal detector illustrated in Fig. 3. This detector has proved its excellence as to ease and stability of adjustment, two factors of prime importance which should be looked for in selecting this item; but any good crystal detector may be used.

The entire set is mounted within a special cabinet with provision for separate battery compartments. The top and center panels of the cabinet are hinged to allow access to the tubes and tuning controls. When closed, the instrument is completely protected from dust and injury.

Close study should be given the photograph of the empty cabinet, Fig. 4, which shows the proper measurements. It is advisable to secure all the material necessary before starting the actual assembly of this receiver.

LIST OF MATERIALS REQUIRED

- 1 Audio-frequency transformer, 4½ to 1 ratio
- 1 Panel-mounting crystal detector, mechanical adjustment preferred
- 2 Special tuned radio-frequency transformers, utilizing—
 - 2 .0005 mfd. variable condensers
 - 2 1/16" Formica forms, 2" long and 2 3/8" dia.
 - 1/4 lb. No. 28 cotton and silk insulated wire
 - 2 8" strips of 1" cambric cloth
 - 8 Switch points and 8 hexagon brass 6/32 nuts for terminals

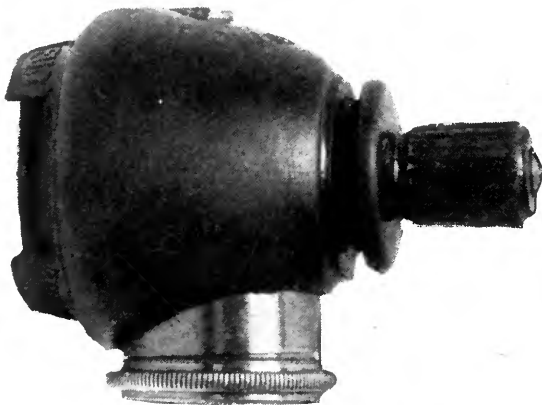

FIG. 3

A small French crystal detector which is gaining popularity in this country. Few are available at present, but they are to be marketed in quantities shortly. The cat-whisker and crystal are completely enclosed. Adjustment is accomplished by rotating the small knob shown at the right

4 3/4" mounting pillars and 4 1" 6/32 round head machine screws for attaching the transformers to the condensers

2 dials to fit condenser shafts

1 Front panel 7 1/2" high, 9" long and 3/16" thick

1 Sub-panel with spun-in socket 3 1/2" x 5" x 3/16"

1 1" Brass angle 3 1/2" long, 3/16" stock

1 Automatic filament-control jack. Micarta insulation

5 Binding posts, 3/8" screws

2 Spring mountings for Amperite or fixed resistance

4 Feet of bus bar

2 Feet of No. 23 bare copper wire

2 Feet of small flexible cambric tubing

8 3/8" 3/32 round head machine screws

8 3/8" 3/32 flat head machine screws

1 Vacuum tube, preferably a UV-201-A or C-301-A

1 45- or 90-volt B battery

1 A battery of 6 volts, either storage battery or dry cells

1 Headset or loud speaker

ANTENNA EQUIPMENT

Either 1 light-socket antenna attachment or

200 Feet No. 12 rubber-covered copper wire

3 5" glazed porcelain corrugated insulators

1 Lead-in insulator

1 Lightning arrester (not necessary when antenna attachment is used.)

CABINET MATERIAL

4 pieces 7 1/2" x 8 1/2" x 1/2"

1 Base 9 1/2" x 18" x 1/2"

1 Top piece 2 1/2" x 18" x 1/2"

1 Cover 7" x 18" x 1/2"

2 Doors 4 1/2" x 7 1/2" x 1/2"

2 Front pieces 7 1/2" x 4 1/2" x 1/2"

THE TUNED R. F. TRANSFORMER UNITS

SPECIAL care should be observed in constructing, or purchasing (if you do not care to build them), the tuned radio-frequency transformer units, as successful operation is greatly dependent upon them. For this reason exact specifications are given, and it would be well to employ similar material, follow the same constructional lines, and make all connections in accordance with instructions if duplication of the results mentioned above is expected.

Procure 1/8-lb. of number 28 single cotton (under) and single silk (upper) insulated soft-drawn copper wire and two formica forms 1/16 inch thick, 2 inches long and 2 5/8 inches in diameter.

Number 28, S.C.S.S. wire is chosen because it combines highest efficiency with exceptionally neat appearance. The double covering provides good spacing between the metallic conductors. The white cotton protective layer affords good insulation, while the silk layer is pleasing in appearance and does not allow the shellac to gather and harden between turns. The usual effect of increased distributed capacity resulting from the use of shellac or other dope on ordinary cotton covered wire is thus reduced.

It is interesting to note that when coils, especially cotton covered, are not treated with some form of moisture-resisting material, a relatively great amount of moisture will be absorbed, the insulation between turns is materially reduced, and this fairly low-resistance shunt across the coil is extremely detrimental to sharp tuning.

The particular size wire is chosen because with it a relatively small length of wire is required for any given inductance and in addition the value of capacity between turns and therefore the total value of distributed capacity is lower than would be the case with heavier wire.

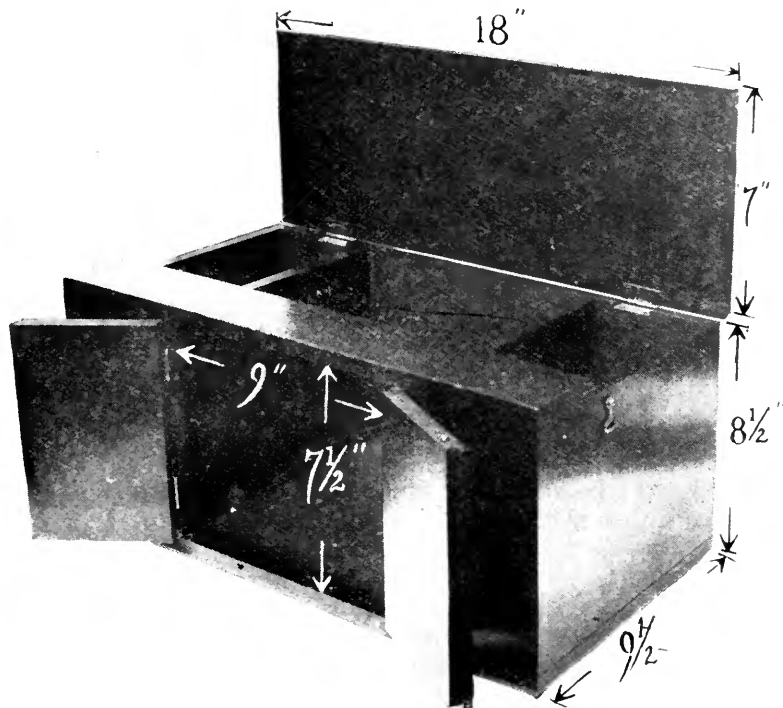

FIG. 4

The receiver slides into the middle compartment, the side sections being provided for the A and B batteries. If the constructor of the set prefers not to make the cabinet, it may be bought for a reasonable sum

MAKING TRANSFORMER T1

ONE of the two Formica forms (see list of materials) should be provided

with four terminals and two mounting screw holes, made with a No. 27 drill. The terminals are situated $\frac{3}{4}$ " apart, $\frac{1}{4}$ " from one edge. The mounting holes are $\frac{1}{4}$ " from each edge on a line parallel to the axis and between the two center terminals. The terminals may consist of switch points with the heads outside and hexagon brass nuts clamping them to the form inside. The projecting pieces of the screws are cut off and solder flowed over the nut to prevent loosening. Small holes to pass the wire should be drilled near terminals 1 and 3 (Fig. 1).

The secondary coil is wound on the form first; starting at terminal No. 3 to which the wire is soldered, 60 turns are placed evenly and tightly; the end of the wire is brought through the form at a point opposite terminal No. 4 and soldered to that terminal.

A one-inch strip of cambric cloth or other flexible sheet insulating material is wrapped over the secondary and held in place with glue.

The primary, of 15 turns, is wound on the insulating material, spaced in the center and in the same direction as the secondary.

The beginning is soldered to terminal No. 1 and the end of the coil is brought through the

form at a point opposite No. 2 and soldered to that terminal.

The entire form may be given a light coat of thin shellac, collodion or airplane "dope," leaving only the terminal heads untouched for soldering. When thoroughly dry the transformer is mounted on its condenser—one method of accomplishing this is shown in Fig. 2. Two holes $1\frac{1}{2}$ " apart may be drilled and tapped for $\frac{3}{8}$ " thread in the end plate of the variable condenser. Two $\frac{3}{8}$ " machine screws and small brass pillars are used to support the transformer away from the condenser. The arrangement should be similar to the illustration in order to retain short leads.

MAKING TRANSFORMER T2

THIS transformer is constructed in a manner similar to T1 with the difference that the primary (top coil) has 35 turns.

Referring to the diagram, Fig. 1, it will be seen that there are five connections to T2; the fifth connection is a center tap on the secondary and should be used only if the receiver is to be operated in the vicinity of an interfering station. Otherwise this tap should *not* be

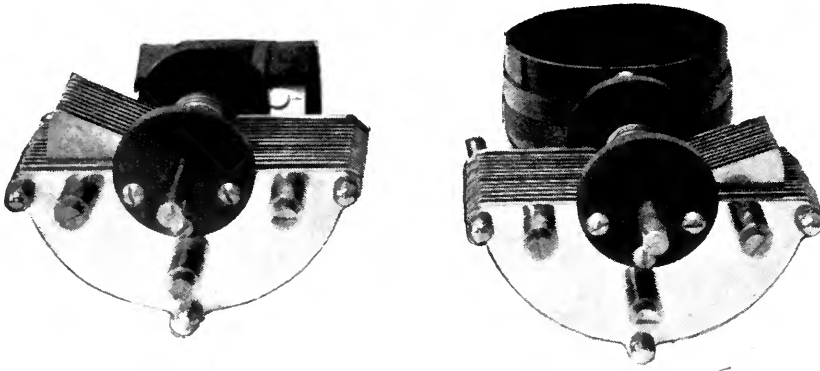

FIG. 5
The tuning units T2 and T1 (left to right)

provided as it reduces signal strength, although at the same time increasing selectivity because the damping effect of the crystal rectifier is effective over only half the inductance; if a vacuum tube detector were used, the value of this connection would be nil, the grid-filament resistance being so high. Although the volume would be diminished, selectivity would be neither greater nor less.

In most cases the lead from the positive B terminal of the primary of T3 will be connected to terminal No. 4 of T2 rather than to the tap.

Only a very light coat of dope or shellac should be placed on the primary of No. 2 as it is desired to keep the distributed capacity very low.

In mounting, T2 should be placed on its condenser at right angles to that of T1. Fig. 5 shows the correct arrangement which should be followed.

The photographs of the back of the complete receiver (Figs. 2 and 6) indicate that the variable condensers face each other; this is not good practice because the dials must then be of different types, one reading left hand and one right hand. Therefore, in the panel layout, Fig. 7, and in the photograph of T1 and T2 (Fig. 5) corrections have been made so that both condensers are mounted in the same manner and both dials may be of the same type. All stated dimensions have been checked and corrected so that the drawings may be followed with perfect assurance that everything will fit.

These special transformers, both T1 and T2, may be purchased if the constructor wishes to save time and labor. They are priced at about \$6.00 each.

THE VACUUM TUBE STRIP

THE vacuum tube socket is "spun" into a sub-panel $3\frac{1}{2}''$ x $5''$ x $\frac{3}{16}''$ on which are located the filament resistance mounting clips, binding posts, audio-frequency transformer and mounting bracket, but single sockets made for panel mounting may be purchased for about \$1.50

and the assembly of the sub-panel will then be up to the ingenuity of the constructor himself. Figs. 10, 11, and 12 will help to show the proper arrangement of parts.

In assembling, care should be taken that the audio-frequency transformer is placed with its grid terminal adjacent to T1; the plate terminal will then be close to T2 so all leads may be made very short.

Four binding posts are located on this sub-panel as indicated in the drawing Fig. 8. This is the correct method in contrast to the photographs which show a receiver with a slightly different wiring system.

Special attention should be given the springs of the tube socket as "dead" tension will in time cause a great deal of difficulty, chiefly characterized by noisy and spasmodic operation.

THE FRONT PANEL

THIS should be of Bakelite, Formica, or Radion, 9" long, $7\frac{1}{2}''$ high and $\frac{3}{16}''$ to $\frac{1}{4}''$ thick. Bakelite or Formica should be sanded or grained on both sides, but Radion should retain its original finish. The panel is drilled in accordance with the front panel layout, Fig. 7, but the position of holes may be changed to suit any condensers.

ASSEMBLY

AT ABOUT this stage in the manufacture of a home made receiver, the amateur workshop, whether it be a real shop, the kitchen, parlor, or attic has assumed an air of congested indecisiveness that hardly bespeaks the usually tidy habits of the constructor; coils, tools, condensers, dirt, sockets, wire, binding posts, solder, and some more dirt and tools are indiscriminately mixed and thrown

about. When it comes to assembling, some of us do not stop to clean up—we merely shove the cluttered mass to one side and with a clear space of six inches go right ahead.

How much better it would be if we were to stop for a few moments, clear up the dirt, put away unnecessary material, and leave before us only the essential parts for immediate progress. Surely the orderly surroundings would tend to create that orderliness of mind which enables better and more accurate work. Let's try it. We should have before us on an otherwise clear table the following parts:

- 1 T₂ transformer unit.
- 1 T₁ transformer unit.
- 1 Sub-panel with binding posts, tube socket, A. F. transformer and resistance mounting clip in place.
- 1 Crystal detector.
- 1 Single-circuit automatic filament-control jack.

1 Front panel, drilled and sanded.

Also a screw driver and 8 $\frac{6}{32}$ flat-head machine screws $\frac{3}{8}$ " long.

The vacuum tube strip is mounted first by threading two screws into the angle bracket (Fig. 9, and at the right in Fig. 10.) The heads should be just flush with the panel. T₁ is mounted to the left of the socket strip, T₂ to the right (from the front). All screws should be driven with a firm and equal pressure in order to avoid unnecessary strain on the condenser shafts.

The aerial binding post is placed in the upper left-hand corner of the panel—this is arranged so connection is made from the rear, obviating an unsightly lead-in. The crystal detector and jack are mounted last; the frame of the jack should be facing down. As the final step in assembling, the dials are placed upon the condenser shafts and so arranged that the movable plates are all "in" when the indicating

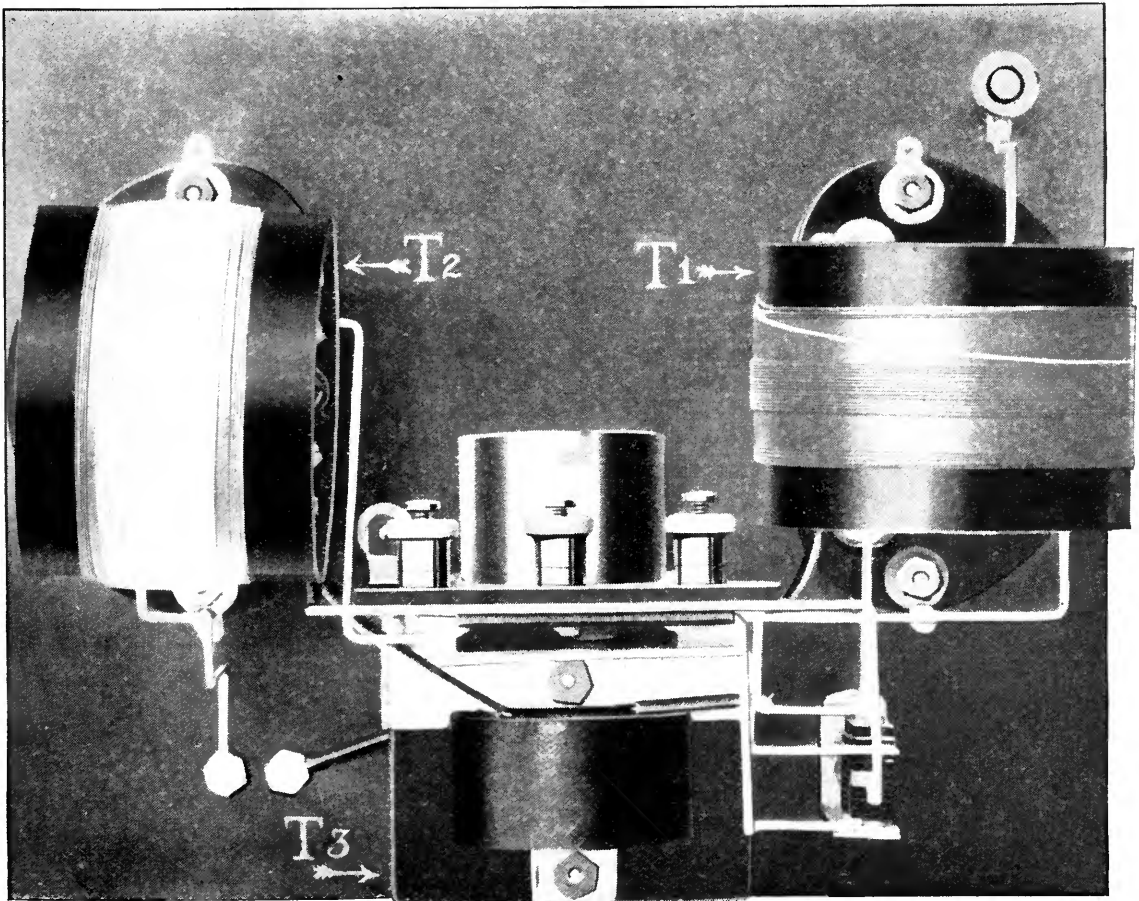

FIG. 6

The receiver as seen from the rear

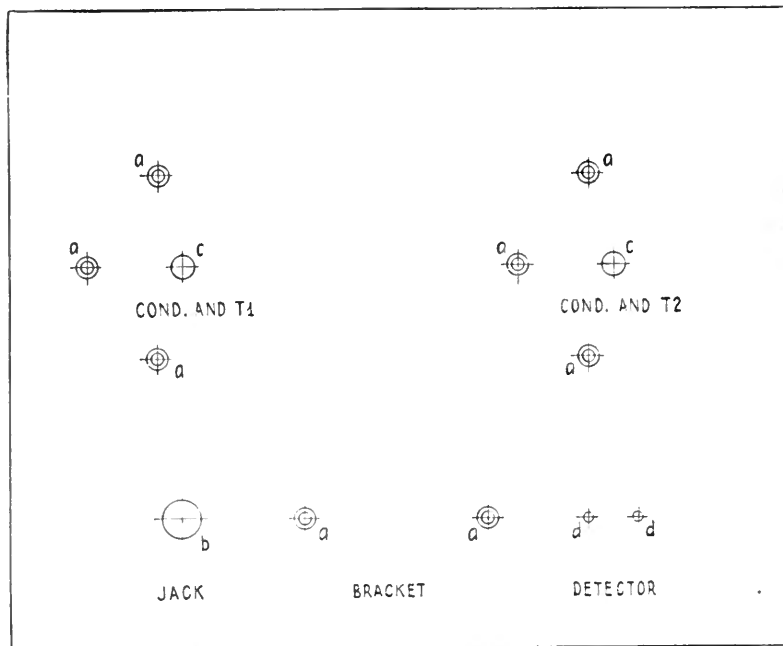

FIG. 7

This plan is $\frac{1}{4}$ the actual size of the panel. For *a* holes, use No. 27 drill and countersink the holes to fit flat-head screws; for *b*, use No. 27 drill; for *c*, use $\frac{5}{16}$ " drill; for *d*, use $\frac{3}{16}$ " drill

mark on the panel is in line with the highest mark on the dial.

NOTES ON WIRING

A GAIN there is need for a clear space, the proper tools, and, if possible, some experience. As every joint must be soldered, a soldering iron is quite essential. So also is a pair of $\frac{1}{4}$ " flat nose pliers, a clean rag and bus bar wire. "50-50" bar solder is splendid, and soldering paste may be used if difficulty is experienced with rosin flux, though the excess should be removed with a little alcohol, after the soldering is completed.

Although each of us has his own way of doing things, the generally acknowledged method of wiring may be condensed in the following seven points:

1—Solder all joints. Soldering to a lug and screwing the lug to a terminal does not constitute a soldered joint—the wire should be soldered direct to the terminal.

2—Flow the solder in all joints so they are perfectly smooth when cold. This requires a properly heated and tinned iron with sufficient flux.

3—Do not be too sparing in the use of flux, but immediately after soldering remove all traces of paste—with scrupulous care.

4—Use square tinned bus bar wire wherever possible.

5—Make 90° bends and run stiff connections only vertically and horizontally.

6—Wires more than a few inches in length should be run against the panel or other insulating support—they should not be left unprotected in space.

7—When soldering a wire to a terminal, aim the wire toward the center of the terminal—do not solder it to the side.

Wire the filament circuit first; the positive A battery terminal runs direct to one filament contact while the negative A battery terminal goes through the automatic

filament control jack break and the "Amperite" mounting (R1) to the other filament contact, thus completing this circuit.

The transformers are connected as follows:

T1—No. 1 to the aerial binding post; No. 2 to the negative A battery terminal; No. 3 to the stationary plates of the variable condenser and then to the grid spring of the tube socket; No. 4 to the rotary plates of the variable condenser and to the "G" terminal of the secondary of the audio-frequency transformer, T3.

T2—No. 1 to the plate contact of the tube socket; No. 2 to the positive B battery binding post. No. 3 to the stationary plates of its variable condenser and to either terminal of the crystal detector; No. 4 to the positive B terminal of the primary of T3 and the rotary plates of the condenser.

T3—"F" to negative A battery terminal; P to the other side of crystal detector. Connecting the negative B battery binding post to the long curved spring of the jack completes the circuit and the receiver is finished!

RESISTANCE STRIPS FOR DIFFERENT TUBES

A MPERITES" or automatic ballast resistances may be purchased in two types; one (PT) for power tubes—that is, tubes drawing 1 ampere; the other (1A) for $\frac{1}{4}$ -ampere tubes

such as the WD-11, WD-12, all the "C" tubes and UV-201-A. The resistance of both types varies with the current in such a manner that slight fluctuations above and below the normal battery voltage do not produce a corresponding change in filament current. This property of varying resistance is the chief asset and, strange to say, the greatest drawback of this type of ballast resistance. For, when a battery is applied to a circuit containing a fixed resistance (such as the filament of a vacuum tube) and a varying resistance such as an "Amperite" the initial current is governed solely by the sum of the value of the fixed resistance and the Amperite—when "cold." And, unfortunately, the resistance of an Amperite is much lower when "cold" than when heated by passage of current—therefore the initial current is in excess of the proper value and is quite harmful to the filament of a tube.

For this reason and also because ballast resistances are not made for all types of tubes we have for some time been using fixed wire resistance strips which may be slipped into the regular mounting. They are easily made, and

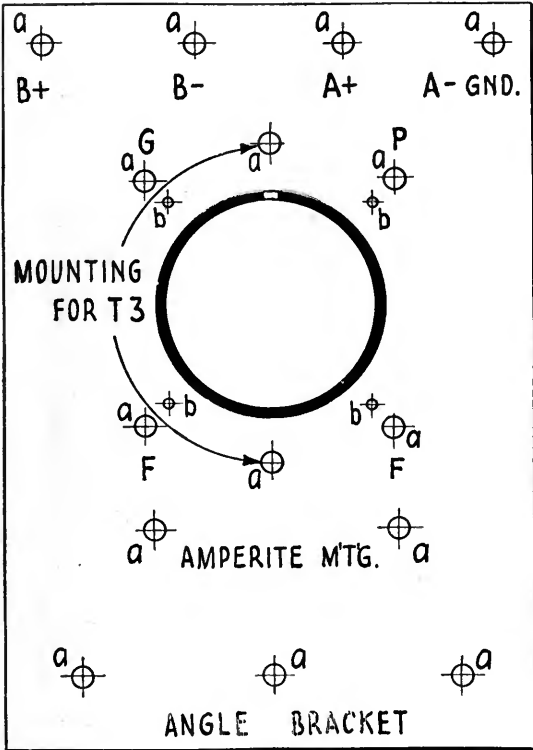

FIG. 8

Plan for the sub-panel. This is in correct proportion, but less than actual size ($\frac{1}{4}$). For *a* holes, use No. 27 drill; for *b* holes, use No. 52 drill

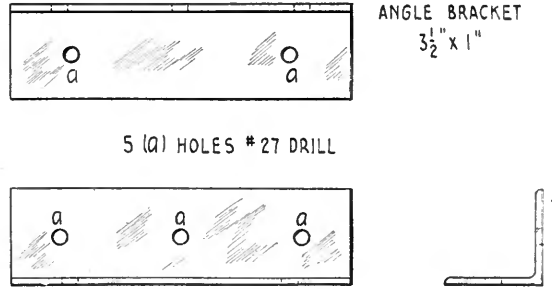

FIG. 9

This is the bracket (half actual size) that fastens the sub-panel to the main panel

with the proper length and size wire may have any value of resistance.

The first few were made from portions of the resistance element of a regular 6-ohm rheostat. Each portion was 2" in length and utilized the resistance wire salvaged from the rheostats.

A much neater job can be made however if $\frac{3}{8}$ " insulating rod cut into 2" strips is fitted with two metal end pieces and wound with the resistance wire, both ends of which are soldered to the end pieces. The rod should be threaded so the wire will not slip and short circuit adjacent turns. Small thumb tacks or similar devices have been employed as connecting end terminals.

It is necessary to know or determine the resistance per unit length of wire in order that the proper amount may be employed to offer the correct resistance.

The following table shows the value of resistance for use with different A battery potentials on various tubes in order to restrict the current to a point slightly below the normal consumption rate.

TUBE	BATT. VOLTAGE (Representing 1, 2, and 3 storage cells and 1, 2, 3, and 4 dry cells.)	RESISTANCE	CURRENT
UV-201-A	6.0	6.0	.23
UV-201-A	4.5	0.*	.22
UV-201-A	4.0	0.*	.20
WD-12	1.5	2.0	.23
WD-12	2.0	4.1	.23
UV-199	3.0	0.*	.06
UV-199	4.0	18.0	.06
UV-199	4.5	30.0	.06
UV-199	6.0	55.0	.06
UV-201	6.0	1.5	.92

*Direct short. May be made like other resistance strips, but has only a copper wire joining the end terminals.

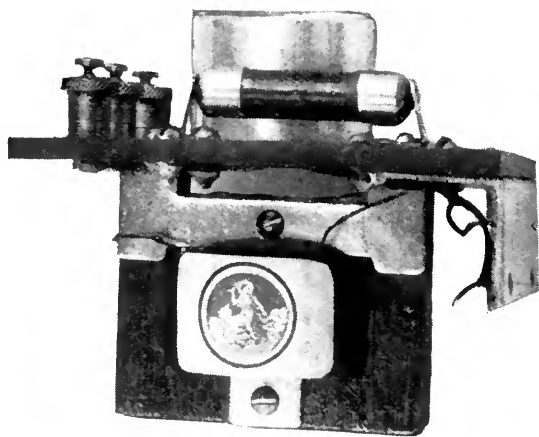

FIG. 10
The sub-base from the left

Having selected a type of tube and the A battery voltage, reference to the table will enable selection of the proper resistance strip. Thus, if a UV-199 with 4.5 volts "A" are chosen, a strip of 30 ohms should be inserted in the sub-panel clips; a WD-11, WD-12, or W. E. "N" tube with a single dry cell will require a 2-ohm resistance, and so on.

Choice of tubes and batteries rests with the constructor; personally we prefer a UV-201-A with 4 series dry cells or a 6-volt storage battery. However, the UV-199 with 3 series dry cells very nearly equals the UV-201-A and is much more practical for dry cell operation. The WD-11, WD-12 and W.E. "N" tubes are of the single dry cell type; they operate quite well but it has been our experience that they come through very irregularly—some being good and others quite the opposite. The B battery voltage may vary from 45 to 90 although with this receiver as much as 300 volts has been applied to the plate of a UV-201-A; the resultant volume being comparable to the output of a single-tube super-regenerative receiver.

THE CABINET

THIS may be readily constructed at home if one is at all handy with wood working tools. Otherwise, it should be purchased.

The left-hand battery compartment is for the filament heating source, and the right-hand compartment for the plate battery. Sufficient room is allowed to accommodate medium size B batteries and full size A dry cells without crowding.

The panel is set back in its compartment 2"

and is held in place with four flat head $\frac{3}{4}$ " wood screws driven into corner blocks $\frac{3}{4}$ " square and 2" long.

Finish is optional, but a dull gloss seems to be popular.

THE AERIAL

PARTICULAR care should be taken in the design of the aerial as, for best results, the resistance should be low. We advise a single-wire aerial, 100' to 150' in length, at least 20' above surrounding objects. The lead-in may be a continuation of the aerial wire and should be brought away at right angles to the horizontal portion. Glazed porcelain insulators are doubtless best for a small receiving system and should be used at all points of suspension.

In the event that an aerial cannot conveniently be employed, reception may be effected with a ground connection alone. This usually will give equal if not better results than a small aerial. The ground should be connected to the aerial terminal and the receiver tuned in the usual manner. Several grounds should be tried—the best type appears to be one in which a rather long lead runs to a distant ground; this is, in effect, a grounded aerial with the receiver connected to the free end. The lighting system may be employed in a similar manner through use of an "antenna

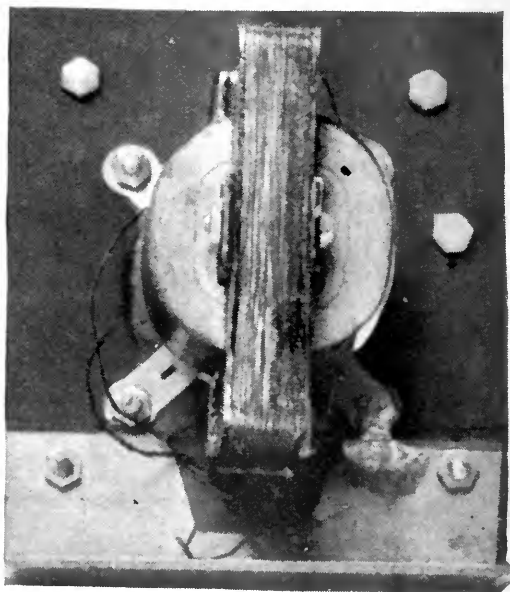

FIG. 11
The sub-base from below

attachment"—if results are satisfactory the more or less cumbersome aerial may be dispensed with.

INSTALLATION

(A) Connect both A and B batteries to their respective binding posts—care being taken to have the polarity correct. Use number 18 or heavier rubber-covered stranded wire and keep all leads short and direct.

(B) Insert the vacuum tube and Amperite in their sockets and ascertain that positive contact is assured; it would be well to bend up the socket springs slightly in order that they may exert considerable force upon the vacuum tube pins.

(C) Connect a suitable ground to the negative A binding post and an aerial such as described above to the aerial binding post.

OPERATION

(A) Place the output plug in the jack; the vacuum tube should light instantly.

(B) Set both dials to the same point and adjust the crystal detector until a fairly strong "click" is heard.

(C) Slowly vary both dials between maximum and minimum position, maintaining them in approximately equal relation to each other.

(D) When a station is heard, turn the grid variable condenser and center it for stronger response, following this by adjusting the detector for better results.

(E) Further manipulation of the crystal for the most "sensitive" adjustment will improve both the quantity and quality of reception.

(F) With an average antenna, both dials will nearly coincide for any wavelength. No difficulty will be experienced in tuning both circuits to the same resonant frequency, as clicks (from crystal adjustment) are heard only when the grid and detector circuits are in tune with each other; being loudest when the circuits are exactly in resonance.

(G) When the crystal contact is "off," the receiver may oscillate, especially if headphones are used while tuning. There are a few methods of stopping this but as it is rarely annoying special precautions are not necessary.

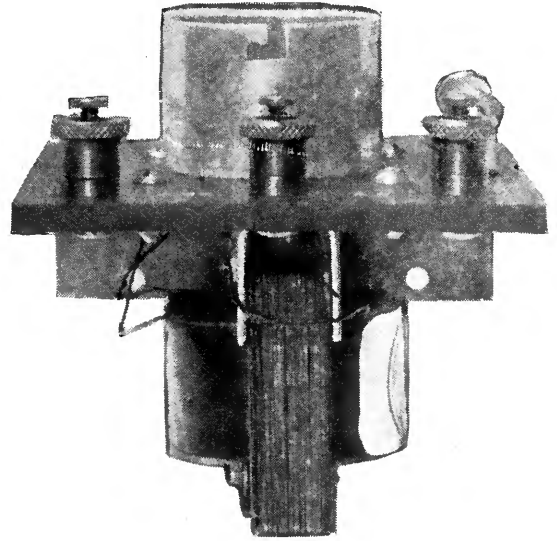

FIG. 12

The sub-base from the rear

(H) On strong signals, the condenser in the crystal detector circuit is not very critical, but it has a well defined maximum resonant peak which may be passed over if this control is varied too rapidly.

(I) It is the *combination* of controls that makes for selectivity, and both are quite critical on weak stations.

(J) The crystal adjustment is important not only for strength and clarity of signals but also for selectivity.

(K) On a stiff piece of manila paper provide three columns to record:

(1) Stations call letters, (2) T₁ dial settings and (3) T₂ dial settings. This record may be permanently placed on the inside of the cover (under transparent celluloid, for example) and referred to when the program of a certain station is to be tuned in.

CARE AND UPKEEP

THE filament and plate batteries should be kept at the proper voltage and B batteries which show a drop of more than 25 per cent. should be discarded.

Inspect all connections occasionally and clean wiping contacts; such as in the vacuum tube socket, in order that there will be no loss due to contact resistance.



WHAT KIND OF NOISE ANNOYS AN OYSTER?

This battery of noise-making devices looks as if it might annoy anybody, but the volume and quality of the sound is arranged so as to seem like the real thing to radio listeners. The players are, from left to right: Lola Sommers, Rose Cohn, Frank Oliver, Edward St. Louis, and Edward Smith. Between Miss Cohn and Mr. Oliver, on a stand, is the bell effect. Mr. Oliver is making it rain cats and dogs with his right hand, and producing the world's most terrifying thunder (on the "thunder-sheet" in background) with his left hand. On the table are dishes for what is picturesquely called "smash effects." Mr. St. Louis is busy with the telephone effect, and Mr. Smith is coaxing the windstorm machine to the limit.

Tricks Used in Staging Invisible Shows

How WGY Puts Across Scenes Without Scenery, Making Many a Home a Theatre. Queer Noise-Producing Devices that Help to Make the Drama Realistic to the Listener-In

By C. H. HUNTLEY

General Electric Company

THE radio audience is, in effect, an audience of the blind. It is evident that if plays are to be presented by radio, the producer must keep constantly in mind that the appeal to the imagination can be made only through the sense of hearing. Merely putting it in touch with the stage of a theatre, therefore, is not enough.

Until about a year ago, such attempts as had been made to broadcast plays were not particularly successful. Individual scenes from plays had been given occasionally, and "The Perfect Fool" and "Lightning" had been put on the air from the theatre in Chicago where they were presented. (That is to say, microphones were placed on or near the stage and the per-

formances were heard just as given.) But the interludes were tiresome to the radio listeners; and the stage "business," visible to those in the theatre, was utterly lost on those who followed the play by radio.

Edward H. Smith, an actor of professional experience, conceived the idea of adapting a play to meet the specific needs of play broadcasting and to solve the problems it presented. He suggested this to Kolin Hager, studio director of WGY, the General Electric Company's station at Schenectady. The idea appealed to Mr. Hager, who stipulated, however, that the play must not take more than forty minutes, as it was to be only one of several features of the program, and the interest of the radio public in such an effort was problematical.

The play chosen was "The Wolf," by Eugene Walter. In cutting down the three-act drama to a play of forty minutes, the second act was taken as the basis, with parts of the first and third acts blended in. A special finale was written. Mr. Walter had insisted that the play be given with a complete cast, and the actors who had had actual stage experience were selected for it. Viola Karwowska played the part of "Hilda"; Frank Finch was "Jules Beaubien"; James S. B. Mullarkey was "Andrew Mac Tavish"; Henry Miller was "Huntley"; and Mr. Smith doubled as "MacDonald" and "Ba'tiste Le Grand." Three of these



MARIE HODGEKINS

A guest artist at WGY, who made a hit in the play, "Under Cover." It is a pity that the radio audience could not see her as well as hear her

actors had previously appeared in the stage presentation of this play.

After several careful rehearsals, conducted as though on a real stage, the play was given. Then came the response, in the form of two thousand letters from appreciative listeners scattered throughout a territory within five hundred miles of WGY, expressing their thanks and approval. The section covered would doubtless have been greater had the play been given later in the season when the static was not such a handicap. Nevertheless, the screams of "Hilda" were so

realistic in Pittsfield, Mass., as they issued from a loud speaker there, that a policeman patrolling his beat hastened to the house from which the sounds came to find out who was being "battered and assaulted."

This first presentation gave the actors some valuable experience. It taught them that the greater the volume of sound, the farther back from the microphone they had to be. As the play neared the end, the din increased to such an extent that the operators of the station tried to soften it by decreasing the amount of power used. The result was that the close of the play was almost inaudible to some listeners. From then on, as an actor raised his voice, he retired farther and farther from the microphone.

So pronounced was the success of this first presentation that it was decided to make plays



EDWARD H. SMITH (Left)

Director of the WGY Players since September, 1922. He has been Director of The Masque, of Troy, N. Y., and did production work with "When Knighthood was in Flower"

FRANK OLIVER (Right)

Since the age of 9 he has been on the stage, principally in Dublin and Glasgow. In the United States, he appeared first in "Treasure Island." He was a pioneer in Biograph motion pictures under D. W. Griffith, and director and scenic artist of the Newark Theatre Guild. In this last connection, he proved himself a painter of no mean ability





AS IT'S DONE ON THE LEGITIMATE STAGE—

An eating scene, staged by Miss Rose Cohn (seated), Miss Lola Sommers (standing), Frank Oliver (standing), and Edward H. Smith (seated)

a regular feature of the WGY program, and to retain the group of actors who had given the initial performance. It was still considered necessary, however, to have plays brought within a forty-minute compass, made up of four episodes of ten minutes each. This time limit imposed considerable difficulty in some cases. For example, it took six weeks to reduce "The Garden of Allah," which consists of ten scenes and takes two hours for presentation on the stage, to the required length. After eight plays had been given, the popularity of drama by radio was plainly so great that the time limit was removed.

Beginning with "The Garden of Allah," the presentation of a play became a part of the WGY program each week, and the WGY Players became a definite organization. In all, forty-three plays, both dramas and come-

dies, had been given up to the close of June, when the regular players gave way, through the summer, to understudies. They have resumed their work this fall.

As showing the appeal this form of entertainment has made to the public, it is interesting to note that "The Sign of the Cross," Wilson Barret's well-known play, which was given by the WGY Players during Christmas Week, brought 1,500 letters in one day, while the total number received in four days was approximately 6,000. Late in July letters of commendation on the presentation of "The Green Goddess," which was presented on March 8, and which in some ways was the most successful of the plays given, were still being received.

The average theatre-goer has at least some conception of the back-stage apparatus used to help produce illusions—the devices for simu-

lating thunder, the roar of an approaching train, the sound of horses' hoofs, and so on. Probably few of the listeners to drama by radio have given much thought as to how the same effects are produced in broadcasting, where they are relatively much more essential because the success of the presentation depends on the appeal to the ear alone. How important the visual factor in dramatic entertainment is, is clear from the popularity of the "movies."

What seem like odd expedients have become commonplace to the WGY Players. One of the most difficult propositions of this kind was met in preparing for the broadcasting of "The Storm." In this play, a forest fire culminates in the crashing of a burning log through the roof of a cabin. To provide the roar of the conflagration, it was at first planned to build a

fire in the rear of the building containing the studio and bring microphones sufficiently near to catch the sound, but on experimenting, it was found unsatisfactory. Gasoline torches were therefore temporarily installed in an adjoining room and provided a very efficient substitute. The crackling of ignited twigs was simulated by crumpling brittle paper in front of the microphone, and to produce the sound of falling limbs, a heavy table was thumped on the studio floor. The final scene, with the collapse of the roof under the impact of the falling log, was made real to the audience by the simple expedient of having one of the actors jump from a table on to a packing case and crashing in the top. It required four men to work these various effects. The result was that, while not a word had been spoken to indicate what was happening, the illusion of a forest fire was per-

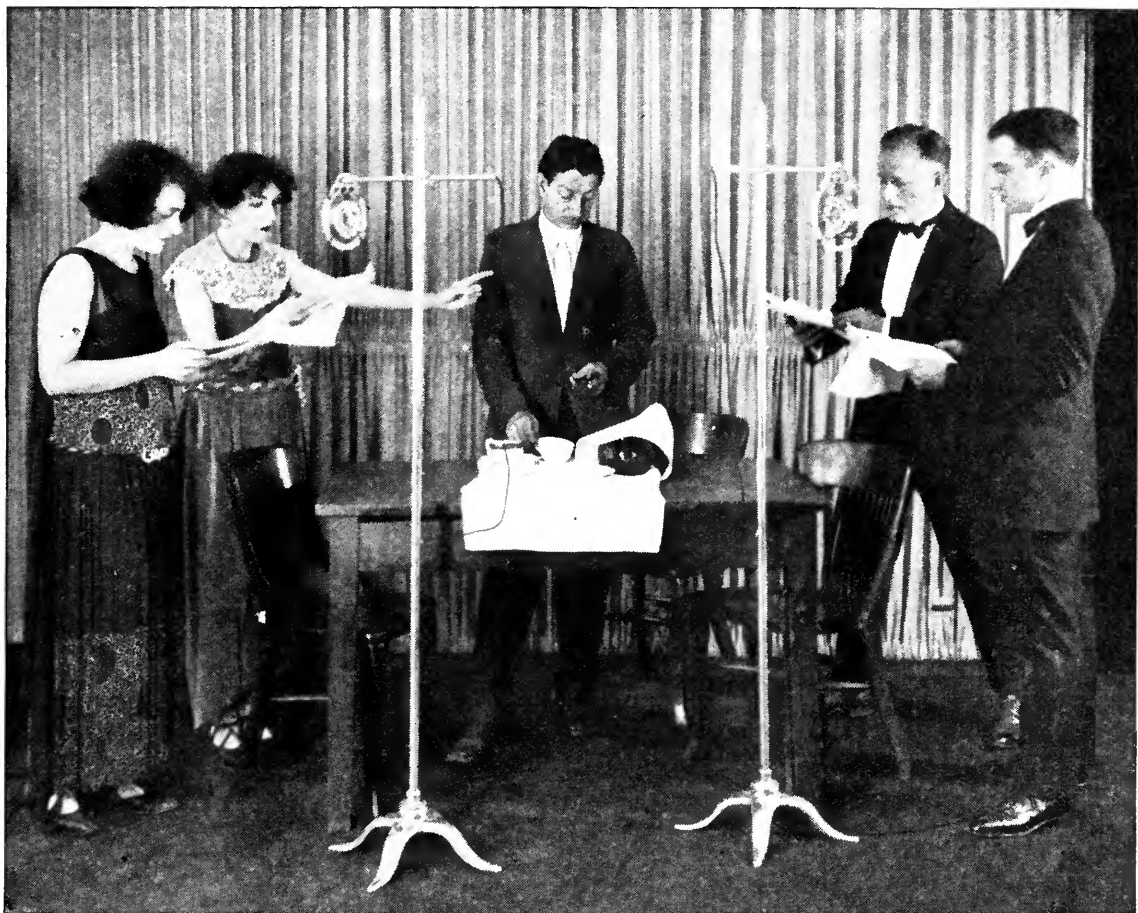

—AND AS IT'S DONE FOR THE RADIO AUDIENCE

The cast is arranged in the same order from left to right as in the picture on the opposite page, with the addition of Edward E. St. Louis (fourth from the left). Mr. St. Louis follows the entire play, the others having individual parts. Mr. Oliver is serving as property man, his job being to produce the rattle of the dishes, silver, etc. necessary to create atmosphere. His part is on the table before him

fect. A man in Nevada wrote that when the tree crashed through the roof, he ducked!

Holding a folded newspaper against the edge of a moving electric fan makes a well-nigh perfect imitation of the droning whirr of an airplane; the rattle of dishes and silver at once conveys the idea of dining; the clink of coins suggests the giving of a tip, and an empty bottle in a pitcher of water at once conjures up visions of ice water. And at the risk of killing the romance for some who have been thrilled by radio dramas, it may be admitted that in the love scenes, the hero plants a kiss not on the lips of the heroine, but on the back of his own hand. Indeed, the hero and the fair lady are often at opposite ends of the room.



Infinite attention is given this matter of sound. If one of the actors is supposed to be talking while eating, he actually eats a sandwich. Wireless telegraph messages are real messages, sent by a bona fide operator by use of a spark set installed for the purpose. The clicking of a telegraph which the audience hears is that of a real sounder operated in the studio. Regulation thunder-making and other devices familiar to the stage are employed, and entrances and exits are marked by the banging of doors.

The members of the cast do not, of course, appear in costume. They read their parts from manuscript, which is typewritten on paper especially selected for its freedom from crackling sound when the leaves are turned, and each actor is furnished with a complete copy.

Reading the parts instead of committing them to memory obviates any danger of forgetting, and makes the presentation smoother than it could possibly be otherwise. Each play is, however, very carefully rehearsed before it is given. In the case of "Madame X," there were four general rehearsals and numerous others for individual players as well. The care that is exercised is evident from the fact that during rehearsals, the players' director, Mr. Smith, is in another room from the rest of the cast when he is not acting a rôle, and hears the play through a receiving set just as it would sound to the great audience. He issues his directions through a loud speaker.

Two microphones are used in transmission, one for men and one for women, this being necessitated by the difference in the quality of

their voices. Voice quality is of the utmost importance in this work. According to Mr. Smith, the ideal voice for the purpose is of low rather than high pitch. The enunciation must be very clear, and *naturally* clear, as any stilted attempt at precision tends to spoil the effect. The value of pause is something that must be learned. The careful actor in this work shades the pauses to almost a fraction of a second. The volume is usually confined to that of an ordinary conversation. If the scene calls for more, the actor steps back from the microphone.

Nervousness, of course, tends to raise the pitch of the voice, but nervousness is not a factor among the WGY Players. Stage fright, even among the amateurs who sometimes take minor parts to complete a cast, has not been noticeable. The whole atmosphere of the studio when a play is being given is one of congeniality, and a performance takes on, so far as the actors are concerned, something of the nature of a rehearsal, inasmuch as no audience is visible. The realization that thousands are listening does, however, spur the players to their best efforts.

That illusion and atmosphere may be created by sound alone, the presentation of plays by radio has definitely established.

In a letter received at the studio following the presentation of "The Green Goddess," a listener wrote: "I want to add my appreciation of 'The Green Goddess' broadcasted last week. It was superb. Maybe I enjoyed it more because I am familiar with the 'Hill Station' region of the Himalayas. You got the local color splendidly. The palace and social life of the Rajah were very vivid. The English 'resident' was perfect, as were also the Major and his wife. The Doctor was just the kind that appeals to all of us."

The radio drama has an advantage over the movie drama in that it is carried right into the home, whether it be an isolated farm-house or a city apartment. Thus, it is available to those who are unable to go out for their entertainment. It creates a stage in every home equipped with receiving apparatus.

Judging from the favor with which it has been received and the progress it has made in a single year, the radio drama will rapidly develop into a recognized branch of the dramatic art.

A Woman Who Makes Receiving Sets

How Mrs. Florence Bethman Became Interested in Radio, Makes Sets for Herself and Others, and Finds Benefit and Joy in Her Work

By ALFRED M. CADDELL

YOU have probably heard of the woman who shod her own horse and fixed her own buggy wheel; and the woman who, when she busted her blunderbuss over the head of an Indian, carved out a new stock and fastened it to the barrel. Also, you have probably heard of women making fancy jewel settings, fixing clocks and doing other things in the mechanical line. But come with me to an attractive little apartment in Brooklyn and meet a woman who not only builds her own receiving sets but has built thirty-six others besides—crystal sets, tube sets, and combination sets of her own design. Not only does she build them—she installs them, doing every bit of the work from making the panels to stringing the aerials. At home she fastens a pair of head phones to the Victrola so that she may tune in a good station and then go about her household duties of making good bread and pie.

Realizing the value and interest that radio holds for women I journeyed to Brooklyn to get a few ideas from this most interesting woman. And I obtained them—more than I bargained for. You know yourself when a woman applies herself to any task and makes a hobby out of it, that hobby is going to be done up in first class shape. You know that when a woman sets out to get a thing, whether it is a trimming for her hat or a knowledge of the way to do something, she is going to get it, and small items like engineering curves and technical jargon serve only to cultivate the impluse rather than to cause dismay. And so it was with Mrs. Florence Bethman—she was determined to bring radio receiving down to earth, subdue the much-talked-about wonder and make it her own. As she put it, herself: "Just because the electron tube eliminates nearly half the radio impulses is no reason why the technicalities of radio should eliminate one-half the people who are interested in it—not when that half happens to be the women!"

One evening almost a year ago, Mrs. Bethman's husband sauntered into a radio shop like a stranger entering the Hall of Fame. He was on the unfamiliar trail of a radio set. He bought some parts and he took them home—with a complete book of instructions. Mount the panel this way, hook up the A battery to the +A and =A posts, the ground wire to the ground post, and so on.

Fine—he would get at it the following evening. Morning came. He went to work. Evening came, and he hurried home to build the set. But something had been going on at home all day—and supper was a little late. On the gas stove was a soldering iron, while screw-drivers, pliers and "spaghetti" also greeted his eye. Moreover the book of instructions looked as if it had seen a season's wear. What had gone on? Smilingly, his wife from the living room beckoned him: "Come here!"

"The first thing I heard," said Mr. Bethman, reminiscently, "was the good old song, 'Swanee River' coming over as plain as day. I could hardly believe it. I had always considered putting together a tube set a little difficult—and it would have been for me. But my wife got impatient and—"

"No, I was very patient," interposed Mrs. Bethman. "I had to be. It took me more than six hours to get the thing working right, and I had to make a trip to the radio shop at that. Fortunately, the man we dealt with knew something about radio and took the time to advise me right. He had a set completely mounted in his store, and pointed everything out, part for part, wire for wire, on his diagram. That helped me a whole lot, and the visualization of his set did the rest. In fact, practically everything I have learned has been through the sense of visualizing, taking a mental photograph of the hook-up of a set, getting the dimensions and constructing things accordingly."

"Even so," I reflected, "visualization or looking at a thing doesn't build one. You must

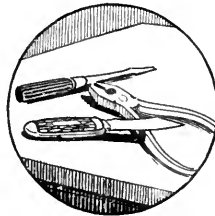



MRS. BETHMAN ASSEMBLING A THREE-TUBE RECEIVER

One corner of a room serves as her "shop." While she is putting one set together, music is often coming in from another set, reproduced with the help of the phonograph horn

have had some knowledge and mechanical skill to build it right. And then there's electricity, the understanding of tuning, wavelengths, grid voltage, resistance and the like."

Unwittingly, I was demanding an accounting—which I obtained very quickly, and satisfyingly.

"My mother had the burden of home mechanics on her shoulders," said Mrs. Bethman. "Father was a shoe manufacturer and strictly a business man. But mother had the ability to reason a mechanical thing out and I think I inherited that faculty from her.

"After graduating from business school, I became an investigator for a sewing machine concern, visiting homes of women who had purchased machines on time, and seeing that they were paid for. In making calls at various homes, women would ask me if I couldn't adjust such and such a thing to make the machine work better. I found that I could and it wasn't long before I knew the whole ins and

outs of a sewing machine. Then when I married and went to housekeeping, numerous odd jobs cropped up as the days went along, and I found it a pleasure to attend to them. A new shelf was needed, an extension light over the bed so I could read; the carpet-sweeper rollers became loose, the key broke in the lock or something stopped the clock. Then the vacuum-cleaner contacts became loose and the insulation wore off. Really, I think most of the things happened on purpose just to keep me fixing them up. But I enjoyed it, and I became extremely confident that I could do almost anything along the mechanical line.

"Of course, you're interested in things about radio. Radio is a simple though marvelous proposition to me. I like it. I like to think of it as a superior sort of art. It brings home (what everyone knows) the

fact that there is something more to this world than our five senses can respond to.

And the science of radio holds a peculiar fascination for me; a wonderful education is concealed in it. It has taught me something about music that makes me think of music in its true light. Music is harmonious vibrations, not simply a combination of tones. Music is vibrations in air while electrical or radio impulses are vibrations in a much finer substance or realm. And to think that human beings have learned how to join sound vibrations with electrical vibrations and convey music and speech electrically—that is a wonderful thing to me.

"I think of radio as simply the rules of the game—how to do it. I picture a voice-patterned electrical wave coming through the ether at the speed of light. Now if I am going to hear it, all I have to do is provide a set according to the rules, and enjoy it.

"But I have found that it pays to experiment.

Experiment and experiment and you will strike a hook-up or arrangement that will have all standard combinations beat—you will bring in the broadcasting clearer and do it with less local battery power. And at the same time you will eliminate much of the static and other noise.

"It takes experimenting to tune in sensitively and get rid of the static. For instance, when I first hooked up a Haynes circuit, every time the elevated train would go by a block or two away, I would get nothing but noise. I had the aerial strung in the specified way with one fixed condenser and a condenser for the phones. I reasoned that this condition must be due to the radiation of electromagnetic or induction waves.

"So I concluded to change things around and make my ground an aerial and my aerial the ground. The water-pipe system of this apartment house was the ground but it is now my very efficient aerial. You could hardly credit the difference in receiving that this change brought about. I account for it in this way: the aerial, being more exposed to the static field proved a better circuit connection when used as a ground than when it was called upon to intercept the radio-frequency waves, while on the other hand the cold water pipe system, surrounded by the steel frame of the apartment house, was less sensitive to static. Of course, I might have it figured out wrong, but I think a good ground is more important than a good aerial and the aerial proved a good ground—at least for static.

"Again, I found that adding two condensers where one was specified improved the quality of reception. And I also found that two B batteries on the plate gave better amplification. I use only the one tube and get Chicago in the winter with ear phones. Listen to that coming in now."

While Mrs. Bethman was talking, WEAf was flooding the room with song. Not through an ordinary loud speaker—but through the Victrola, if you please. Mrs. Bethman had clamped a pair of head phones to the phonograph arm that extends out over the record, after having removed the reproducer, and radio music was pouring forth through the tone chamber. As clear as a bell, too—she had the set tuned "razor edge."



"I have also used the gas stove as an aerial and strung wires all around the apartment," she resumed, "and would like to try running a copper cable in a water pipe to see if greater sensitivity could be had. But besides looking for sensitivity in the aerial and ground I find that a good deal depends on the wiring of the set, particularly when it comes to tight connections, insulation and soldering. Soldering is one of the secrets of success. So many

people think that when they drop a lump of solder over a connection and make it stick, they have made a good joint. Nothing is more erroneous. The copper wires should be made as hot as the solder and care taken to see that the solder runs all the way through the space of the connection, so that it is really fused with the copper. When one thinks of the

sensitivity required to bring in a radio signal, this point will at once become obvious. I have found it so through experience."

"How long does it take you to put a set together complete?" the writer asked.

"With this set, two hours, because it is arranged logically and simply. But I have worked from four to five hours with other sets all depending on the circuit connections and whether or not there are one or more steps of amplification. Most of my experience however has been with my own type of set—so far I have built thirty-six of them for my friends. I enjoyed the work more than I can tell. The feeling of pride that comes with accomplishment is as good as medicine to me. I remember undertaking to build a set for a friend. It was a little out of the ordinary, with a super-regenerative wiring circuit. I had been stricken ill with influenza, but the moment the parts were brought into the house I could not tolerate staying in bed—I must get up and assemble them. And the result was that I speedily forgot that I was sick—I never got over anything quite as quickly in all my life."

"Judging from your experience in building sets, possibly you may have a suggestion or two to offer as to improvement in design."

"For one thing, I should think an improvement in the phones and loud speakers is something that cannot come too soon. I think combination phones with different resistances and different sizes and kinds of diaphragms might help in bringing in various tones that

cannot otherwise be heard. Of course, such a combination would have to be supplemented with a tone mixer in order to produce the best possible harmony. This of course is theoretical in my mind, but if I had the means of experimenting in this field I'd certainly find pleasure and possibly profit in doing so."

Mrs. Bethman opened a bureau drawer to get a screwdriver, and behold! the whole drawer was full of tools, radio accessories, wire and assembled coils and parts. One odd-looking device was especially noticeable. The writer never saw it in any mechanic's kit of tools. It was a rod standing in an upright base, and on the rod was a sliding piece held by a thumb screw. It might have been a laboratory device, useful in an experimental way. But no! It was a dressmaker's gauge. If you were a woman and were having a waist fitted to a skirt, you'd stand alongside a table, when the proper distance was noted on the skirt a piece of chalk would be inserted in the sliding piece and an encircling line made on your skirt. But just as a flat iron is sometimes used as a hammer, so this device found an odd use in the assembling of a spider-web coil—the sliding member was used to vary the coupling to obtain selectivity in tuning!

But the bureau was not the only place when it came to a handy yet inconspicuous receptacle for tools. No, there was a comfortable looking foot-stool, the top of which was really a good size box. Standing on legs which had been cut from the fancy-work at the foot of an old-fashioned wooden bed, and covered with upholstery and cretonne it made a most artistic piece of living-room furniture. And in this box—well, you might imagine what was in it and not be far wrong.

Certainly, Mrs. Bethman doesn't have to go borrowing when it comes to soldering irons, drills, hammers, and other tools. Indeed, she takes great pride in her little collection of soldering equipment alone.

"Most of these things were given me by the men of the company where my husband works. For besides him, other officials have taken a decided interest in radio. But many of them either did not have the time or did not want to experiment with a radio set. So I had the pleasure of doing it for them, and in appreciation they saw that I had all the various tools that I needed, or could use in an apartment. They certainly get a wonderful lot of good out of radio."

"Besides the pleasure derived from building sets and experimenting, have you obtained much knowledge from what comes over via radio itself?"

"Yes indeed! Would you like to try some health bread that I made from a recipe that came via radio? Besides good health advice, including breathing and dieting, I have heard some splendid travel talks. Personally, I have traveled all over the United States and certainly enjoy it when I hear the scenery of Yosemite Valley and Yellowstone National Park described. With joy, I live all over my travels again. When the guide led me (and other radio fans) through the Grand Canyon of the Colorado I experienced a thrill that I shall never forget, for he described a scene so perfectly that I think he must have overheard me describing it to a friend! Yes, travel is one of the beauties of radio. Only if you happen to be a wife also, be sure that you put plenty of water on the beans or the potatoes before engaging in a travel tour by radio.

"Radio has certainly broadened my interest in a great many things that I scarcely would have been interested in before," she says. "For instance, sports: I like the returns of the various games and races. If any one would have told me two years ago that I would become interested in prize fights I would have promptly denied the allegation. But I have and it's all through listening-in. However, it is not the prize fights that interest me so much as the crowd psychology behind them. And the cheers that are picked up by the microphone! When excitement reflecting this crowd psychology can be made to live, and you feel the intensity of it all—then that to me is a different thing. The other evening about twelve of us listened in on the returns of a fight, half of whom were women, and we enjoyed the excitement as well as the men. It made radio stand out as so much bigger a thing than a newspaper account—real, true and full of life!

"And then the music. I have certainly learned a lot about who wrote various compositions, when they are announced. And I've heard the same selections played in so many different ways! I have a very good ear for music and have been able to reproduce many of the radio selections on my piano. Radio has certainly broadened my repertoire of musical numbers."

"Have you found many women interested in radio?"

"Of late there have been quite a few, but of course from the listening-in standpoint mostly. I do not know of any other woman who builds sets or otherwise tries to learn the secrets of radio. But there aren't so many secrets that one need be afraid of trying to master the combination of good reception, for combination it only is. One part has to work in perfect unison with another, and once this harmony is secured I know of nothing that will bring so much variety and happiness as radio. This set here has not cost me more than \$40 at the outside and the upkeep is practically nothing. Music, speeches, travel talks, lectures, and various topics of the day—where else can you get such a variety of knowledge and entertainment?"

Listen to Mrs. Bethman: "My folks up in a little town on the Hudson wouldn't take \$100 for their set if I couldn't make them another," she said. "Besides entertaining them night after night, it has saved them a lot of money."

"Saved them a lot of money?"

"Yes, everyone has to have some form of entertainment and education, and when they can select anything they want by their radio set they do not care to go to the movies or come to town to the theatre. I have nothing against the movies or the theatre and neither have they, but what they can get via radio and the science of the art itself has been an everlasting attraction to them. They have a pair of phones clamped on to their Victrola too, and mother and dad sit out on the porch until way long after midnight some evenings listening to the broadcastings of this station and that. It's a great treat to them, I tell you."

The technical discussion of radio holds great interest for Mrs. Bethman. Although she cannot at present go deeply into curves and capacities and other engineering pastimes, she has an exceptional grasp of radio affairs, understands the action of the electron tube and knows the whys and wherefores of the various parts of her set. "I am going to get a

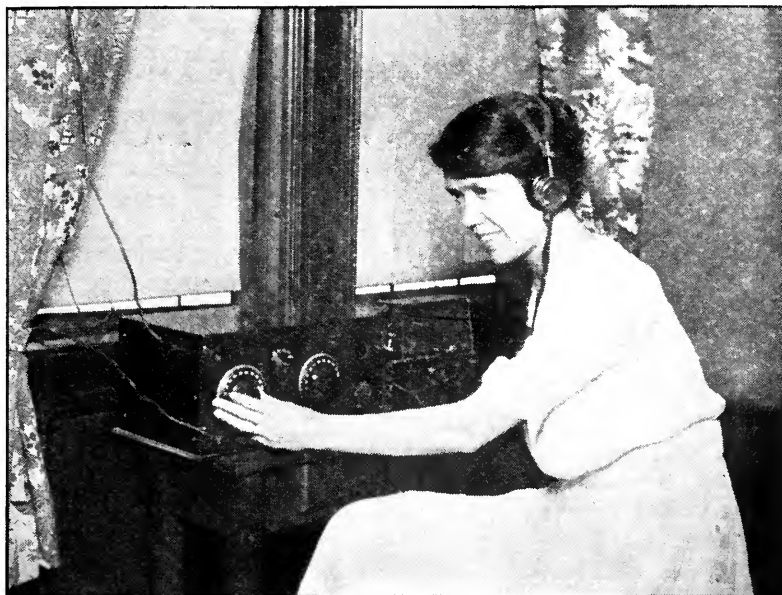

SOMETHING SPECIAL, JUDGING FROM MRS. BETHMAN'S EXPRESSION
This set is one of the thirty-six which she has made

lot out of this little receiver" she says, "and have already proved that I don't need two steps of amplification in order to hear through the sound box of the phonograph. But I haven't obtained maximum efficiency with it yet."

If radio is a hill of achievement to-day, to-morrow when it becomes of greater interest to women, it will become a mountain. From the women's standpoint, understanding radio seems to be the hardest part. Wiring diagrams scare them. The sudden avalanche of electrical terms does the same. Years ago when carburetor, differential, and similar terms were ushered in with the automobile they had a similar effect. But the popularity of the automobile made these terms familiar to all. Surely it will be the same with radio terms. Moreover, as Mrs. Bethman pointed out, when dealers learn how to sell radio more intelligently themselves, there will come about a better understanding of the art, and with understanding—feminine popularity.

"I don't know what I'd have done if I hadn't received information and advice from a well-informed radio dealer," Mrs. Bethman says. "He took exceptional pains to see to it that I did things right. But it has paid him well—thirty-six sets resulted from our first purchase, and probably many more that I do not know of."

Which speaks very loud for all who have ears to hear.

Stray Capacity: When You Want It and When You Don't

By JESSE MARSTEN

ALTHOUGH the presence of stray or distributed capacity in radio is recognized among the amateur fraternity, its importance is often overlooked or minimized owing to

the fact that the values of these capacities are very low as compared to the lumped capacities used. However, the absolute magnitude is no indication of the importance of distributed capacity, as there are cases where extremely small capacities in the wrong places produce distressing effects. It should be borne in mind that they cannot be controlled and varied at will like lumped capacities and that they often make their appearance in the most unexpected and inaccessible places. It is for these reasons that the subject is of sufficient importance to merit discussion.

Any two conducting bodies which are at different electric potentials will have electric lines of forces between them and may be considered as the two plates of a condenser. Where electric conductors are purposely placed near each other to produce this condenser effect, we have what is called a "lumped" capacity. Where this capacity effect is produced unintentionally, we have what is called "distributed" or stray capacity. Thus in any radio set any two conducting bodies will have capacity between them; and unless proper precautions are taken it may produce harmful results.

Where do stray capacities occur, what effects have they, how may they be used to advantage, and how may they be minimized?

The effects of distributed capacity are greatest in inductance coils, because each turn is at a different potential from every other turn and therefore forms a miniature condenser with every other turn, the sum total of these miniature capacities making up the total distributed capacity of the coil. This must be taken into account in measurements and designs; otherwise large errors and losses are bound to occur.

Since a coil has distributed capacity, it may be rightly considered as an inductance and capacity connected in parallel, as in Figure 1, where an inductance coil, with its distributed capacities shown in dotted lines, is shown equivalent to a pure inductance with a shunt

Possibly This is the Reason Your Receiver Doesn't Work

"One often reads an amateur's tale of woe, somewhat like this," says Mr. Marsten, "'I built a regenerative receiver, but somehow can't get it to oscillate no matter how tight my feed-back coupling is. What is the trouble?'"

"The trouble frequently is that somewhere in his tuner there is a coil whose distributed capacity gives it a natural period of vibration equal to the period at which he is trying to regenerate. But, since this coil is naturally tuned to this frequency, it absorbs so much energy that regeneration is impossible or greatly reduced. This does not mean that there is an unused coil knocking around somewhere inside the receiver cabinet. The principal offender is the unused portion of the primary of the variocoupler."

Perhaps, like many others, you are attempting to use variometers with entirely too much wire on them, or you are attempting to use a receiver over a broad band of wavelengths without taking the precautions against losses which are very likely to occur.—THE EDITOR.

capacity C. An inductance coil will have a natural period of vibration since it constitutes a radio-frequency circuit having inductance and capacity. As a result, if a coil is connected to a circuit in which there is radio-frequency energy at its own natural frequency, the coil will absorb a considerable part of this energy since a condition of resonance is produced. This energy will be wasted unless this condition is purposely brought about. The coil need not be directly connected to the circuit for this to happen: if it is only in the vicinity of the circuit the waste will occur from induction.

This is one reason for the poor results obtained from many receivers built by amateurs or even marketed commercially to-day. Fig. 2 shows a typical single-circuit receiver widely advertised by manufacturers. A coil BC, having a large number of turns, is tapped and connected as shown. Consider for a moment the broadcasting range of wavelengths. With the average antenna, only a small part of the coil AB is generally required to tune to the required wavelength. It will be observed that there is a portion of the coil not actually used in reception and it often happens that the inductance of the unused portion or even the entire coil with its distributed capacity tunes to the received wavelength. As a result, the incoming energy which strikes the antenna is largely absorbed and wasted by the coil BC and not all of it is passed on to the telephones. This phenomenon is naturally more likely to occur in receivers which attempt to cover a wide range of wavelengths. In these tuners therefore, owing to the large amount of coil

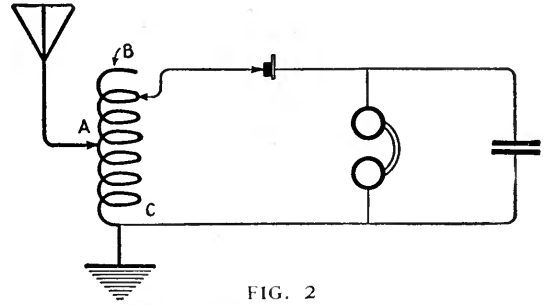

FIG. 2
A typical single-circuit receiver

maximum transfer of energy from the antenna circuit to the phone circuit and maximum efficiency in the broadcast range.

This effect of absorption and wasting of energy by coils is present in regenerative receivers also. One often reads an amateur's tale of woe, somewhat as follows: "I built a regenerative receiver, but somehow I cannot get it to oscillate no matter how tight my feedback coupling is. What is the trouble?" The trouble frequently is that somewhere in his tuner there is a coil whose distributed capacity gives it a natural period equal to that at which he is trying to regenerate. But since it naturally is tuned to this frequency it absorbs so much of the energy that regeneration is impossible or greatly reduced. A tuned circuit like this is equivalent to placing a very high resistance in the feed-back circuit which prevents the current from flowing properly. Too much resistance will, of course, prevent oscillations. In regenerative receivers covering a wide range of wavelengths, it is desirable, in order to avoid such effects, to build the various coils in small sections disconnected from each other, but connected electrically by necessary dead-end switches. Each of these sections should be so designed that the natural wavelength or period of vibration is less than the lowest of the wavelengths at which recep-

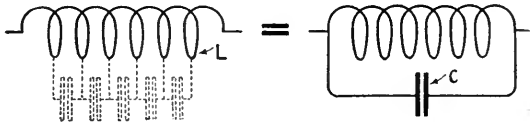

FIG. 1

present but not used, the efficiency is very low unless some means is provided to offset this condition.

Such receivers, or any receivers, for that matter, can be most efficiently designed for a narrow band of wavelengths. A good way to design the single-circuit tuner is as shown in Fig. 3. The circuit is designed to have maximum efficiency on a small band of wavelengths. The entire coil BC is a small coil whose distributed capacity will not give it a natural period equal to any in the range of frequencies covered. At the same time it has enough inductance to reach the highest wavelength desired, which should not be more than 500 to 600 meters, and also has the right amount of inductance for coupling purposes. The coil is tapped as usual, and no matter where point A is, coil BC will not absorb energy since its natural period is under the lowest of the waves received. Finally, by carefully designing coil BC, its construction may be such that its inductance, distributed capacity, and the capacity of the phone circuit will make it resonant to about 380 meters, thus securing

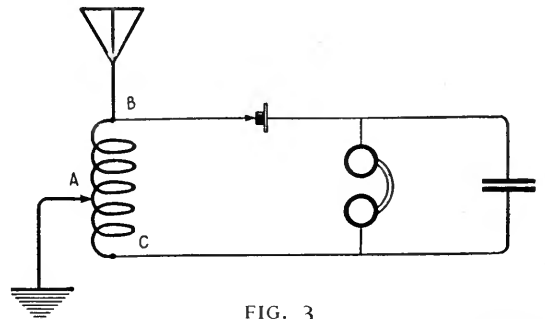

FIG. 3
An improvement over the arrangement shown in Fig. 2

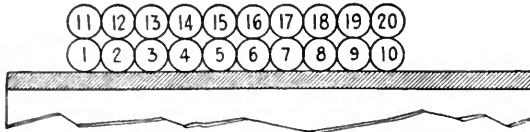

FIG. 4

tion is made. In this way absorption of energy is minimized.

Much of the loss in distributed capacity is due to the dielectric of the distributed capacity being poor. The miniature "condensers" in a coil virtually comprise a large condenser in which a flow of current takes place exactly as in any lumped condenser. This current flows through the dielectric of the condenser which in the case of the distributed capacity of the coil is the shellac, enamel, or other insulating material around the wires. This dielectric is, of course, a very poor one. Although it may possess sufficiently good insulating properties for direct currents, it passes high-frequency currents and much energy is lost in the form of heat in the dielectric. It is therefore desirable to reduce the distributed capacity in coils as much

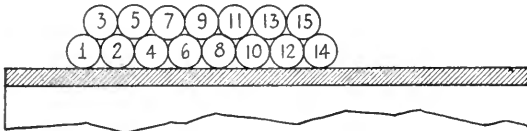

FIG. 5

as possible. Numerous methods of coil winding have been developed for this purpose. The smaller the difference of potential is between contiguous turns the smaller will be the capacity between these turns. A single layer coil will generally have the least distributed capacity since the difference of potential between any two turns is a minimum. However, in any other type of coil the difference of potential is larger. Consider a two-layer coil as in Fig. 4. Here the difference of potential between a wire in the second layer and one directly underneath it is equal to the difference of potential between all the turns between them and is, of course, much greater than that between two turns next to each other in the same layer. This is why most compact multi-layer coils have a high distributed capacity. The principle in the reduction of coil capacity is to wind the turns so that any two contiguous turns will have as small a potential between them as possible. Fig. 5, showing the so-called "banked" winding, illustrates how this

is done. Instead of winding first one complete layer and then the next as in Fig. 4, turns in each of the layers are wound alternately. Fig. 6 shows a three-layer banked winding. By this method, the difference of potential between adjacent turns is always not more than that between a few turns. Thus the distributed capacity is reduced.

The presence of distributed capacity in coils has considerable effect upon the accuracy of

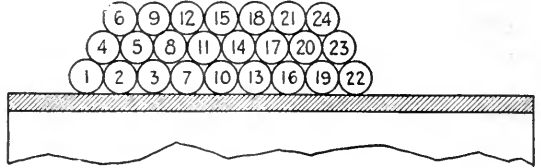

FIG. 6

measurements made with the coil. It will be evident that when large lumped capacities are used in parallel with the coil the effect of the small distributed capacity will be negligible. But when small capacities are used in parallel with the coil, the effect of the distributed capacity becomes greater since its magnitude begins to approach that of the lumped capacity. In other words, distributed capacity exerts its greatest influence at wavelengths which are small and near the fundamental of the coil. It is for this reason that measurements of the inductance of coils will be liable to great errors if taken near the fundamental with small lumped capacities. Measurements should therefore be taken at wavelengths requiring the use of large shunt capacities, because the distributed capacity masks the true inductance of the coil and gives it an apparent inductance higher than its true value. As the wavelength increases, the masking effect becomes smaller and smaller, and the apparent inductance approaches the true inductance.

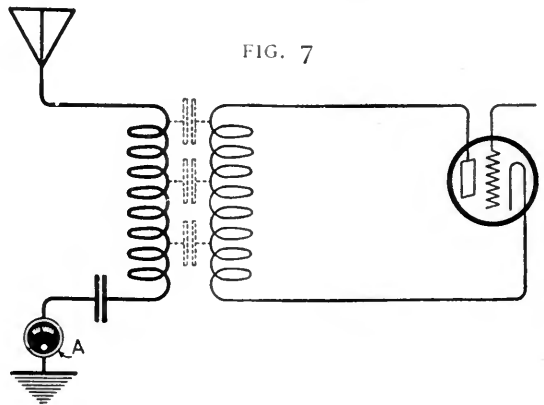

FIG. 7



42ND STREET AND THE THEATRICAL DISTRICT, FROM THE TRANSMITTER HOUSE

This photo happened to be taken when the station was broadcasting music from the Hotel Astor Roof, which is seen brightly illuminated at the right of the picture. The horizontal dots in the background are lights on the Jersey shore

Behind the Scenes at a Broadcasting Station

By CARL DREHER

There are times when quick decisions and rapid work are demanded of the operating personnel at a broadcasting station. The average listener-in knows little of the complications, and of the incidents both amusing and trying that make up the operator's daily life. Mr. Dreher, who is in charge of the Radio Corporation's New York station, says: "Looking at the apparatus in all its complexity, and revolving in one's mind the number of things that can go wrong, one is surprised that it ever works at all." People, too, cannot always be relied upon to do the things expected of them. How the artists, as well as the apparatus, are handled so as to maintain a smooth and satisfactory program for the broadcast fan, is told in this article.—THE EDITOR.

A CERTAIN broadcast listener was disturbed one day by the testing of a couple of amateur phone transmitters in his vicinity. For about half an hour two zealous experimenters recited each other's call letters, the story of Mary and her lamb, and a list of the defects in their modulation, which were many and various. Although the amateurs were on their legal wavelength, this conversation mingled inextricably with the music from a commer-

cial broadcasting station whose program interested the listener. Like the situation in Kipling's ballad when two strong men meet face to face, in radio, when one is close enough, there is neither East nor West, wavelength or frequency or tuning—just QRM. The broadcast listener, vastly and understandably annoyed, did not pause to analyze the facts of the situation. He sat down and wrote to the broadcasting station:

"How do these private talks get into your

amplifying room to be broadcasted, instead of the advertised programs?"

To this inquiry our friend appended many bitter complaints. The notion that the trouble lay in the location or electrical characteristics of his receiving set apparently never occurred to him.

Another gentleman suffered with a receiving system which was capable of picking up signals, but without prejudice as to wavelength; its tolerance was such that it did not differentiate very well between 405 and 455 meters, and consequently there was considerable interference, in this listener's set, between WJY and WJZ. The listener knew that these two stations are located at Æolian Hall in New York, as the halves of a duplex station, but he did not know that the two programs are radiated from separate sets, separate aerials, and separate studios, with inappreciable cross-talk between the two wavelengths. He sought and found a simple physical reason for the interference which he experienced, informed the broadcasting station of his observations, and berated the technical staff soundly with this rhetorical question:

"Why . . . don't you close the doors between the studios?"

Having been a radio man for many years, I have little respect for myself or other members of the fraternity. Still, they have more sense than that; they really have.

Complaints also come in by telephone. The conversation usually begins as follows:

"Something's wrong with your modulation. Are you listening in?"

Informant is assured that three men are listening in, and that it sounds all right at the transmitting end. After a few minutes of conversation it develops that the receiver is howling. The trouble is not usually at the broadcasting station; if it is, the operators are aware of it. When there is something rotten in Denmark, the Danes are apt to know it.

THE JOB OF KEEPING A STATION GOING

NOT that the broadcaster is never at fault. Looking at the apparatus in all its complexity, and revolving in one's mind the number of things that can go wrong, one feels surprised that it ever works at all! Yet it works



NOT TOO MUCH HERE TO OBSTRUCT THE WESTBOUND WAVES

View taken from the base of the Æolian Hall towers, looking toward Hoboken and San Francisco. At the left is the Wurlitzer Building, with Bush Tower behind it, then the Candler Building, Times Building, and the unfinished Times Annex. Beyond flows the beautiful blue Hudson

successfully almost all of the time; after less than two years of commercial existence, metropolitan broadcasting is substantially on the level of operating efficiency of other public utilities. This in spite of the fact that radiotelephony presents problems of unique and inherent difficulty to the engineer. The slight energy of the voice and of musical instruments, in all its complexity of pitch, quality, articulation, inflection, and shading, must be amplified to power level, and this final half-kilowatt of radio power which is flung out from the aerial of the transmitting station must be a faithful reproduction of the original feeble acoustic vibration. To accomplish this, not only in the laboratory, but for a reliable grade of public service, is probably a more difficult job than running an electric railroad, say, for here we start and end on the power level; or manufacturing wrist watches, for in this instance we work with small energy and no great demands in the way of power will ever be made on the system. The object of this article is to give readers some idea of how carefully the various energy transformations are checked in a well regulated broadcasting station, what precautions are taken against interruption of service, and what, in general, goes on during the day's work.

The work may be divided roughly into three parts. First, the picking up with a microphone or other acoustic-electric device of the sounds to be broadcasted. Secondly, amplifying this energy and putting it out on the air. Thirdly, listening to and observing the output, and finding fault with it if possible—for if any faults exist, and the station critics don't find them, outside critics will. Broadcasting is in one way a division of the show business, and the luxury of nursing their weaknesses in private is denied to professional broadcasters, as to politicians, actors, and multi-millionaires. They always have the comforting thought that their mistakes will be heard and noted by the general manager and a squad of directors of their own corporation, besides a few chief engineers and such, besides some score of professional musicians with an ear for what drops out and what is over-emphasized, besides the emissaries and representatives of rival broadcasting stations, besides a few hundred thousands of the general public. Consequently the work of checking the output of the transmitters is not the least important part of the job. The place where this is done—the control room—is

in fact the heart of the station, and while the station is in operation the control operators have supreme direction of what is to be done, and how, and when. G. H. Q. is in the control room.

THE ARRANGEMENT OF STUDIO AND APPARATUS AT ÆOLIUM HALL

IN THE description which follows, station WJZ of the Radio Corporation of America, at Æolian Hall in New York City, will be used, that being the station which the writer happens

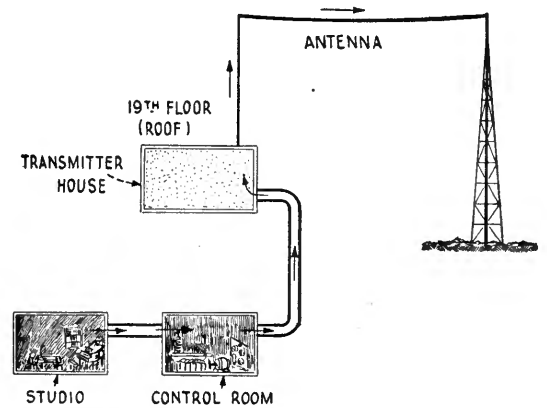

FIG. 1

to know more or less intimately. The layout of this installation is rather unusual. It is shown schematically in Fig. 1. The studios, reception rooms, and control room are located on the sixth floor of an eighteen-story building. The actual sets and all the power equipment—motor-generators, storage batteries, etc., together with the aerials, are on the roof. The necessary connections are made through a mass of pipes or conduits carrying insulated wires, installed according to the best electrical practice. Of course all wireless stations are prolific in the matter of wires, but as one stands in the sixth-floor corridor, near Forty-Second Street, and gazes at the row of black pipes stretching out to Forty-Third Street, thence rising majestically up the freight elevator shaft a few hundred feet, before going half way back to Forty-Second Street to the transmitter house on the roof, and reflects on the number of wires each pipe contains, the name "Conduit Central" springs to one's mind as a fit alternative for the station's official cognomen of "Broadcast Central."

In Fig. 2, a schematic view is given of the control operator's equipment. There are six single-step amplifier units, of which not more

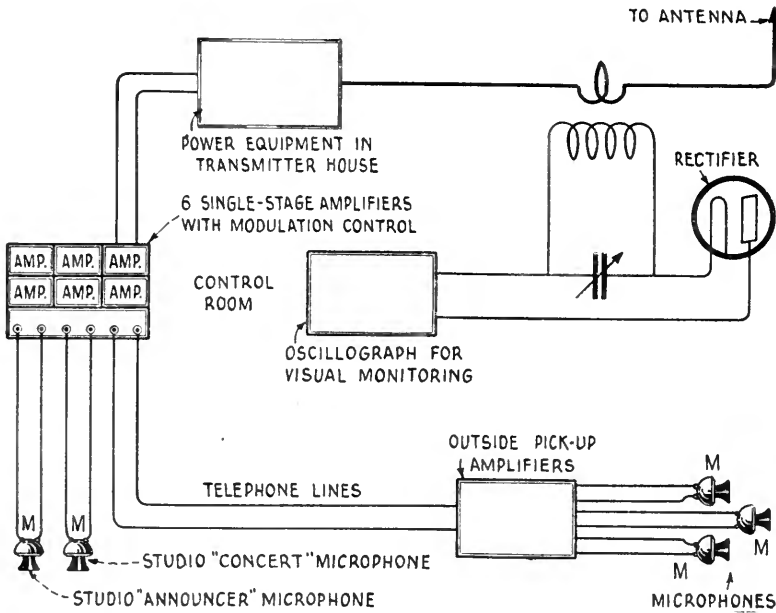

FIG. 2

A schematic diagram of the control operator's equipment

than two are used at any given time, the remainder being spares. Four of these amplifiers are intended for use in connection with the studio; two are for outside work. By means of plugs and jacks similar to those on a telephone switchboard, and a set of knife switches, the control operator can connect either studio microphones or outside lines to his amplifiers and send the output upstairs to be progressively amplified to power level and put out on the air. The plates of all these single-stage units in the control room are connected and all that is necessary is to give the unit input energy and to light the tube. In the transmitter room, coupled to a single turn in the antenna lead, there is an edgewise-wound copper ribbon inductance, which draws a small amount of energy from the aerial to actuate an instrument in the control room, called an oscillograph. This apparatus gives a faithful picture, in the form of a light ray thrown on a revolving mirror, of the sound wave impressed on the radio oscillations sent out from the station. By means of it the control operator can ascertain at a glance what the state of his modulation is, and make any indicated changes. "How much is she modulating?" or, less elegantly, "How much is she kicking?" is one of the most frequent questions asked in any broadcasting station. At many stations the answer is a matter of guesswork, but at WJZ the control

operator can answer: "Forty per cent. average; seventy per cent. peak," or whatever the figures are, just as if he were reading temperatures on a thermometer, or miles on a speedometer.

This matter of per cent. modulation is important enough to warrant an extended description, of which only a brief outline will be given here. It amounts to this: You have a certain amount of radio frequency—say 500 watts—to put out on the air. This energy is not itself audible. All that people can hear is the variations produced in the radio-frequency output by the sound waves impressed on the latter. Modulation is the business of varying

the radio frequency in accordance with these sound waves. If you undermodulate, no one on the outside hears you. The available energy of the station is not being used. It is like investing one's \$500,000 in a project yielding interest at the rate of $\frac{1}{4}$ per cent. The investment would probably be perfectly safe, but one could not entertain many Follies girls on the income. If you overmodulate, everyone on the outside will hear you, but it would be better if they did not, for what they will hear is like a combination of bricks sliding down a chute, the songs of amorous cats, and the war cry of the noble red-man. This is equivalent to investing one's 500 talents in a bootlegging enterprise, getting caught by the revenue officers, and losing both one's patrimony and one's freedom. There is a happy mean which is at the same time audible and safe. The control operator must find this mean and stick to it, or to-morrow he gets fired. (However, even if the per cent. modulation is well gauged, the control operator has a number of other means of getting fired.)

Fig. 3, in its several divisions, shows what may be seen in the revolving mirror of the oscillograph. There are three straight vertical lines, the left-hand one being the zero line, the right-hand one marking 100 per cent., with a median line indicating 50 per cent. A wavy line formed by the reflection of a beam of light

on the revolving mirror, by the extent to which it fills the space between the two extreme marks, indicates the measure of modulation. In Fig. 3a, the modulation is low—about 10 per cent. corresponding to a pianissimo passage in music. In Fig. 3b, the modulation is 60 per cent.—a good, audible value, with adequate margin for most exigencies. Fig. 3c, illustrates a bad case of over-modulation.

But now, instead of continuing our description in the regulation way, let us proceed from this bare outline of the equipment, and fill in the details by telling the story of a composite day in a control operator's life.

AN AVERAGE DAY IN THE LIFE OF THE CONTROL OPERATOR

WE WILL call him Jim. Jim wakes up at about ten o'clock in the morning, for he worked the evening before till after eleven, and probably took out his girl, or a

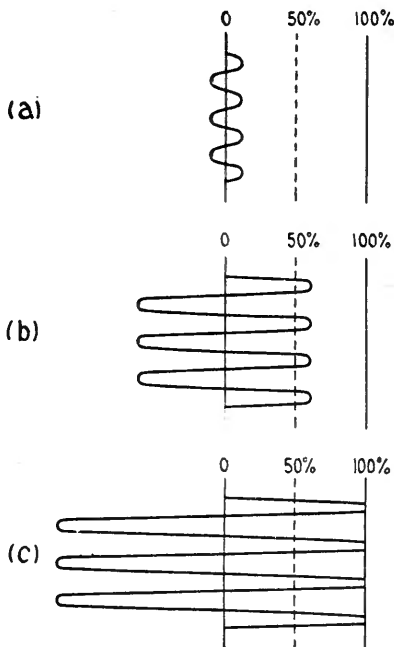

FIG. 3
Low, good, and too great modulation, as indicated by the oscillograph

plurality of girls, after that. He breakfasts in bed while glancing at the radio programs in the morning papers. However, we are not concerned with Jim's activities until, after two o'clock, his limousine rolls up to the Æolian Building. Ascending in the elevator, he observes a number of musical celebrities, for this building is one of the chief musical centers of New York, and makes a mental note of the latest fashions in flowing scarfs before getting off at the sixth floor and entering the control room. Here some of his own colleagues are already seated, earnestly discussing the rotten modulation at all the other stations in the country, the faults of the announcers, means of making broadcasting pay, and the grave error of the executives of the company in not immediately doubling the salaries of the whole staff.

At 3.00 p. m. the program is scheduled to



"HIS OWN COLLEAGUES . . . DISCUSSING THE ROTTEN MODULATION AT ALL OTHER STATIONS, The faults of the announcers, means of making broadcasting pay, and the grave error of the executives of the company in not immediately doubling the salaries of the whole staff"

start. Shortly before this time the control operator throws a number of switches, putting current on the microphones and tubes, and, drawing aside a curtain, he glances through a horizontal window into the studio, where the announcer is conferring with the first artist, a red-haired soprano, regarding the numbers she is to sing. At fifteen seconds before three o'clock the control operator lifts the receiver of a small intercommunicating telephone before him, rings the roof, and gives the order, "WJZ on the air." Or he may use the local designation of "Channel B." An instant later a green signal light glows on the amplifier rack in the control room and also in the studio, notifying the announcer and the control-room operator that the transmitter is on the air and ready for the program. As yet, however, nothing but inaudible C. W. is going out. Several other signal lights are put on at this time, but

these have no material part in the working of the station, communication between the several rooms being by interphone.

Observing the green light on his table, the announcer sits down and throws on his microphone by setting a small cam switch at "Announce." This lights a red bulb in the control room and also in the transmitter house, warning all hands that speech is about to go out. The announcer then gives his preliminary speech, introduces the artists, and throws his cam switch to "Concert." The music begins. The control operator, who has paid only casual attention to the announcement, for he is familiar with the announcer's speech and has his apparatus properly set beforehand, is now very much on the alert; he turns a knob rapidly, puts out the room lights in order to observe the oscillograph better, and peers through the window at the scene in the studio. Appar-

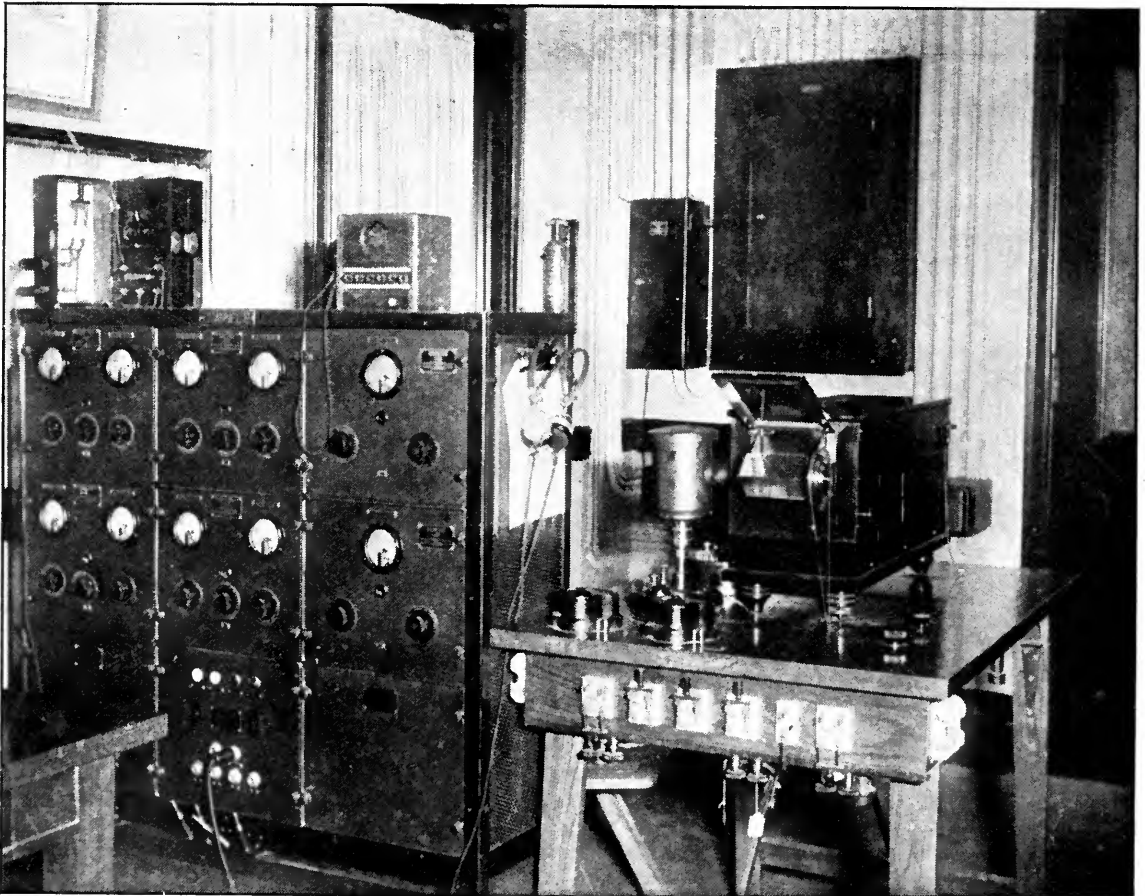

THIS IS WHERE JIM PUTS IN HIS EIGHT HOURS A DAY

A section of the control room at "Broadcast Central," Aeolian Hall. The amplifier rack, with the interphone unit on top of it (for talking with "the roof" and the studio), is seen at the left. At the right is the oscillograph with its four-sided mirror in which the voice pictures appear

ently he is not satisfied, for he holds the telephones tightly to his ears, and even mumbles inarticulate comments to himself while listening. Finally he calls the studio on his interphone and says, "Too much piano; but let it go till the end of the number." This is a matter of judgment. If the microphone is moved during the number a jarring sound goes out on the air, and the artist may be somewhat disturbed in her singing. As the accompaniment is only slightly too loud in proportion to the voice, Jim has decided to defer the change to the end of the first selection. Perhaps he was influenced by the singer's red hair. At the end of the number the announcer gives the usual formula: "The number you have just heard is—" and throws the cam switch to the "Off" position. The red light goes out and the station is momentarily inactive, although the oscillators are still on the air and the green light glows as before. Before continuing with the next number the announcer moves the microphone pedestal so that it will pick up less energy from the strings of the piano and more from the singer's vocal cords. He may do this by asking the singer to stand nearer to the microphone, or by shifting the microphone to a position farther from the piano. A frequent setting for vocal solos is shown in Fig. 4. The change being made, the concert continues.

KEEPING IN TOUCH WITH THE ROOF

A WORD about the interphone system of calling. The telephones on the roof, in the control room, and in the studios, are equipped with the usual buzzer system of ringing, but in the studios, where silence is imperative, a white light on the telephone unit glows for calling. The announcer answers by lifting the receiver off the hook and listening. The control operator hears the receiver being lifted and makes his request. The announcer acknowledges receipt by tapping his transmitter twice, forming the code letter "I", which passes in radio and wire circles for "Received"; this procedure is inaudible in the studio, but perfectly clear to the control man. In the absence of this signal, the control operator repeats his instructions till they are understood. This system has worked out well in practice. In case of a matter requiring a consultation of any length, the control operator may call the announcer into the adjoining control room.

During the second number of the red-haired soprano's repertoire Jim confines himself to

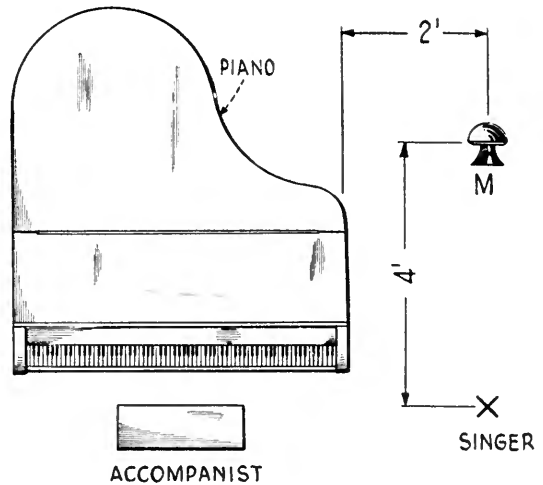

FIG. 4

This arrangement has been found suitable for vocal solos

adjusting modulation, bringing up his "gain control," as it is called, on very pianissimo passages, and "holding her down" to prevent over-modulation on the forte notes. However, he does not attempt to level out the music or to edit it in any way; on the contrary, his business is to put out on the air, as faithfully as possible, the material given him in the studio, making only such adjustments as are required by the nature of the media, physical and electrical, intervening between the artist and the audience. This is easier for some artists than for others. In general, performers with experience in phonograph recording are the best to handle. They realize that they are singing in a room and not in an opera house, and graduate their volume accordingly. The apparatus and the operators are grateful to them and they go out well. Others sing with enormous volume in the hope of reaching New Zealand, but of course they do not get out any louder and there is a tendency to overload the microphone, with the production of a scratching sound, more or less prominent, which detracts from the quality of the voice on the air. However, within considerable limits the operators can compensate for inequalities, and the usual answer to the question, "Shall I play or sing in any special way?" is, "No; perform in your natural manner, and it will get out best."

HELPING THE PERFORMER "GET OUT" WELL

THE control operator is aided in his work if he knows most of the songs that are apt to be rendered, and has enough knowledge of musical composition to know a few seconds



"IN THE HOPE OF REACHING NEW ZEALAND"

ahead when a fortissimo passage is coming. This is in fact one of Jim's qualifications, and it preserves him from ever being caught flat-footed when the artist pulls out the stops and takes it on high—to mix three metaphors—and under these conditions it would take an earthquake to over-modulate when Jim is holding down the channel. To a certain extent, also, he may rely on his judgment of the artist's vocal capacity; but this is apt to be treacherous. The writer remembers one occasion when a very small coloratura, with whom he did not have the honor of any previous acquaintance, started on her first number in the studio. She had a beautiful radio voice, but did not look dangerous in the matter of volume, after some fairly bulky girls who had preceded her. The writer made his settings accordingly. In a few seconds she hit 85 per cent. on a peak. The writer was familiar with the aria and knew there were some fortissimo breakers ahead, but he did not think that the artist could get up any higher. This thought, unfortunately, had no basis in fact, the lady swept up to her high note with astonishing force, modulating

about 150 per cent., and before anything could be done the plate relay on the transmitter tripped and the set shut down with a squawk. The spare set was on the air in five seconds, but the writer felt like a tennis player who gets a soft lob at the net, sets himself to bury it, and slams it into the backstop. Well, accidents will happen when one is dealing with strange coloraturas and judges them by weight.

After Mademoiselle has got through with her program, there is a talk on fashions. This item gives Jim little concern, and when one of the announcers brings in the soprano to look over the control apparatus, Jim is able to tilt one of the phones off his ear and to monitor with the other side while explaining the functions of all the lights and knobs. Of course she wants to know how she went out, and here Jim applies his code. If she was fair, he tells her that she was good. Good he calls wonderful. If she was really wonderful, words fail him. If she was bad, he says he wasn't listening. But even that is not necessarily a discredit to the artist, for occasionally one hears a voice which is good concert material and makes a fine impression in the studio, but does not transmit well, owing to some obscure acoustic factor which does not affect the human ear as much as it does the microphone.

WHEN TUBES GO BAD DURING A PROGRAM

TOWARDS the end of the fashion talk, however, Jim notices a slight muffling in the voice, which leads him to call up the transmitter room with the question: "Are your modulator tubes gassing?" The transmitter men have already noticed as much, and they proceed to push a few buttons and start the spare set. A slight click on the air marks the change-over, and the signals clear up at the same instant. While the second set is carrying the load, the defective tubes may be replaced in the first set. If there were not two sets available the trouble could not be rectified without interrupting the program. In a first-class broadcasting station everything is provided in duplicate or better, and kept ready for service at a few seconds' notice.

The next feature on the program is a five-piece jazz band. Jim already knows the characteristics to expect from this ensemble, and he places the violin close to the microphone, the saxophones somewhat farther back, and the traps and banjo to the rear. After the

first number a few minor adjustments in placing may be necessary.

Jim's real troubles begin when he has an outside event to broadcast. All that the public knows about it is the announcer's request to stand by while the program is switched from the studio to such-and-such a place umpty-ump miles away, a 15-second pause, and the voice of the announcer at the new scene of action. But there is a great deal of action behind the scenes.

In the studio there is a well-known pianist. Owing to slight but cumulative delays in the program, the studio is running five minutes behind its schedule. At 8:30 a symphony orchestra of one hundred pieces is to be broadcast. The wires have been in for several days, they have been tested a few hours before the beginning of the concert, and since 7:30 Jim has been on the line at intervals, talking to the pick-up men, listening for extraneous noise on the wires, and so on. It is 8:29. The pianist is in the middle of his last selection.

"Say, Jim," comes the voice of the chief pick-up man, "I've got to have the air. They're going to start."

"It's only eight twenty nine and a half," replies Jim, stalling for time. "He's on his last number. Just a second and I'll give it to you."

"I can't wait a second," declares Bill, on the outside. "We've got 8,000 people here. The conductor's glaring at us. For heaven's sake give us the air."

Jim begins to sweat. He looks through the window at the pianist. He looks at the announcer, who lifts his index finger—one minute more. Will the number never end? Of course Jim could take the piano off the air without the performer knowing it, but the audience would know it, and the pianist's relatives who are listening on the outside would tell him before very long. So the plug remains in. The outside men, in the meantime, are making appealing gestures at the conductor. If he should

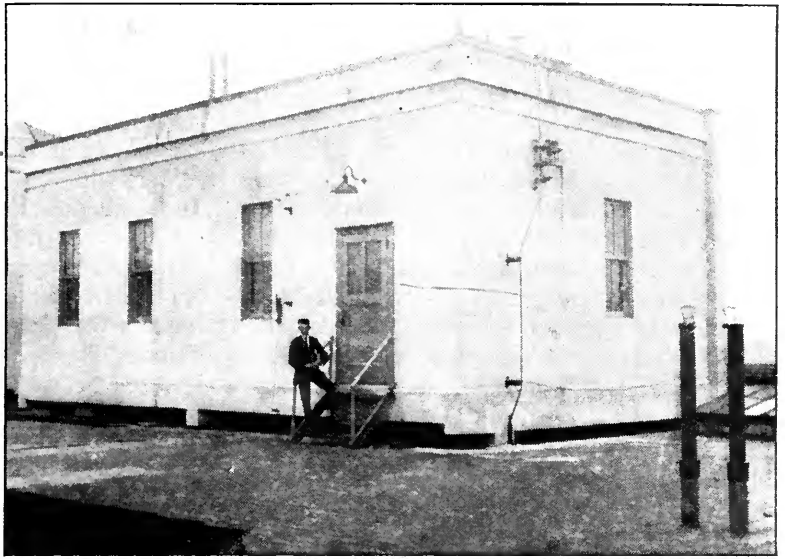

THE TRANSMITTER HOUSE ON TOP OF AEOLIAN HALL

It is here that the voice currents from the studio and control room, thirteen floors below, are amplified and delivered to the antenna, part of which can be seen in the upper left-hand corner of the picture. The announcer in the studio, the operator in the control room, and the transmitter house personnel keep in constant touch with one another by means of a special telephone system

start, the first number of the symphony program, which will take 15 minutes, will be lost. By running over two minutes at the studio, the station stands to lose thirteen minutes on the air, with nothing to fill in, and the certainty of losing the audience to other stations with attractive programs. At 8:32 the pianist finishes. As the local announcer finishes his say Jim pulls the plug, leaps to his telephone, calls, "You're on the air," and closes the switch which connects the distant microphones to the set on the roof. The voice of the concert announcer is heard, and an instant later the symphony begins. Jim monitors this locally, with the pick-up men making adjustments at their end, and the transmitter men on the job upstairs. There may be as many as five men checking on one channel.

In the intervals the wire is used for conversation regarding the wire line transfer between the control room and the pick-up point. If Jim neglects to pull the switch, this stage business goes out on the air. Occasionally this happens, and the radio audience hears directions like: "Change to 440 loop; this wire's getting noisy," or, "Hey, haven't they got any string instruments in that orchestra?" But this is a rare occurrence.

So the program runs its course—vocal

numbers, instrumental numbers, jazz, opera, talks, recitations, symphonies, time signals, bedtime stories, plays—anything that the program manager has reason to believe will please some considerable fraction of the audience. As closing time approaches Jim has listened to a hundred thousand words about the income tax, international relations, the boll weevil, love and marriage, the preparation of prunes, how to keep one's good looks if one never had any, why the army should be enlarged, and measures to stop the next war. He has heard arias from every opera from

Orpheus to The Girl of the Golden West. He has had six fights with announcers bigger than he is, been challenged to duels by four outside pick-up men, received twelve very insulting telephone calls from listeners who were wrong and three moderately insulting ones from listeners who were right, and ogled twenty pretty girls, all escorted and inaccessible. Promptly at 11:30, with the last syllable of the sign-off, Jim collapses and is dumped into his limousine to be carried home. Let the invisible audience drop a tear for him next time they slip on the "cans."

THE MASS OF STEEL AND MASONRY EAST OF AEOLIAN HALL

The aerial towers rise 115 feet above the roof from which this picture was taken, thus clearing all these buildings. The Biltmore Hotel (with flag flying) is seen at the left, the Commodore pushes up against the sky-line in the centre, and the banks and business buildings which cluster around Madison Avenue and 42nd Street form the walls of a "Grand Canyon." The dark patch at the bottom of the "canyon" is the motor-traffic bridge leading around Grand Central Terminal joining the up and down-town sides of Park Avenue. A bit of the East River and some power houses on the Brooklyn shore may be seen in the background. This is the kind of territory over which the radio waves must travel and into which they must penetrate



The "Dope" on Wavelengths and Kilocycles

If you are not familiar with the relation between wavelengths and kilocycles, here is the opportunity to get it into your head in a few minutes. The information is likely to come in handy from time to time.

THE current radiated from the aerial of a broadcasting station is *alternating* in character: that is, instead of having always the same potential and the same polarity (like the current from a dry cell, for instance), it is constantly changing in these respects, building up from zero potential to a maximum, or "peak," of positive polarity, and then "collapsing" to zero and building up to a similar peak of negative polarity. Such a current is represented in the accompanying diagram. It alternates very rapidly—at radio frequency, as it is called. A *cycle* is a complete reversal of alternating current from a positive peak down through zero to the negative peak and up through zero again to the next positive peak.

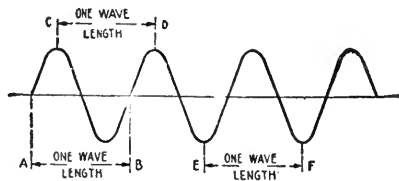

The number of *cycles per second* is called the *frequency*.

The physical distance between two successive peaks of the same polarity is called the *wavelength*, generally measured in meters. These waves travel through space at the speed of light—186,000 miles a second or 300,000,000 meters a second. Now, if a wave makes 1,000,000 complete reversals a second (that is, has a frequency of 1,000,000 cycles, or, 1,000 kilocycles), it will make *one* complete reversal in $\frac{1}{1,000,000}$ of a second; and in $\frac{1}{1,000,000}$ of a second, any given peak (being part of a wave always traveling at the rate of 300,000,000 meters a second) will move through space a distance of exactly 300 meters.

A station transmitting with this 1,000-kilocycle wave, then, is said to be sending "on 300 meters."

Here is the equation for changing wavelength to kilocycles and vice versa:

$$\text{no. of kilocycles} \times 1,000 = \frac{300,000,000}{\text{wavelength in meters}}$$

For example, if a certain wavelength is 400 meters,

$$\text{no. of kilocycles} \times 1,000 = \frac{300,000,000}{400} = 750,000, \text{ or}$$

$$\text{no. of kilocycles} = \frac{750,000}{1,000}, \text{ that is, } 750. \text{ (See table below).}$$

The following tables give the frequency in kilocycles for various wavelengths:

FREQUENCY IN KILOCYCLES	WAVELENGTH IN METERS	FREQUENCY IN KILOCYCLES	WAVELENGTH IN METERS
1,500	200	333	900
1,000	300	300	1,000
750	400	200	1,500
600	500	150	2,000
500	600	100	3,000
429	700	75	4,000
375	800	60	5,000
		30	10,000

To check up a certain wavelength with its corresponding frequency, multiply the frequency (kilocycles x 1000, because one kilocycle equals 1000 cycles) by the wavelength. The result should be 300,000,000.

What Causes Fading?

By CAPT. P. P. ECKERSLEY

Chief Engineer, British Broadcasting Co.

THE phenomenon of "fading" has been known to wireless engineers for some time, but the advent of broadcasting has brought the subject into great prominence.

There may be those, fortunately situated in relation to one of the broadcasting stations, who have never experienced fading; so, at the risk of redundancy, I will try to explain first what I mean by the term.

You are listening to a station 150 miles away when all at once the signals go dead, or weak. You fly to the regenerative control, but everything you do has no effect, when suddenly without warning the sound bursts out again. The number of people who have conscientiously soldered, tightened and tuned, and scratched their bewildered heads, must be legion, as the number who write in, having satisfied themselves that *their* end is all right, and complain of the variability of the transmissions, is certainly considerable.

As a matter of fact, the transmissions by the British Broadcasting Co., are *not* variable, and except where light and shade are desirable in musical items, radiation and modulation are maintained sensibly constant.

The cause of the variability lies, therefore, between the transmitting station and the receiving station.

The question is, then, what is there to influence the attenuation of the waves so markedly and so variably? Why in certain places does London fade while other stations do not? Why is fading noticeable only at night, and why should night time signals be stronger than day time signals in certain places and not in other places? Why should 2 LO be audible only a quarter of an hour after sunset in Salamanca, Spain, and why

should the Shetlands get us pretty uniformly, while people in the Victoria district (no! London, not B. C.) experience fading effects which are never noticed, say, in Hampstead? The answer is easy as far as I am concerned, and it simply is, *I don't know!*

But a general theory exists which I will give you, and which probably forms a basis on which to build the explanations of minor variabilities.

First of all, wireless waves travel through the ether, which is the assumed medium for the transmission of all electro-magnetic waves. This medium is not in any sense of the word matter, inasmuch as matter is ponderable and can be analyzed, weighed,

felt, and experienced by the human senses as it were. The ether is perfectly non-conducting to electricity, and to our senses it is nothing. But floating about in the ether are minute particles which in various permutations and combinations form matter—air, water, earth, and so on. Now, if matter is conductive to electricity, it impedes the progress of electromagnetic waves traveling through the ether which holds matter. Thus, if the air which is suspended in the all-pervading ether is conductive, it impedes wireless waves. It may come as a surprise to many to know that air can be conductive; it is not usually necessary to suspend the filament terminals of your set in a vacuum, but air *can* become quite conductive, and especially does it become so under the influence of sunlight. What happens is that the little particles called molecules in the air are made lively by the sunlight and split up into electrified units, which make possible the conduction of electricity.

Thus, in the accompanying diagram I have drawn a rough sketch of the world, with the

The phenomenon of "fading" becomes more noticeable as the cold weather, with its long-range reception, approaches. Broadcasting from a given station may be remarkably loud one minute and almost inaudible the next. Adjustment of the receiver will not overcome this trouble and it is very naturally the subject of much discussion and conjecture. In this short article, reprinted from *The Wireless World and Radio Review*, London, the author explains in simple language one of the generally accepted theories.—THE EDITOR.

THE EARTH

Showing the action of the sun's rays in producing an electrified layer

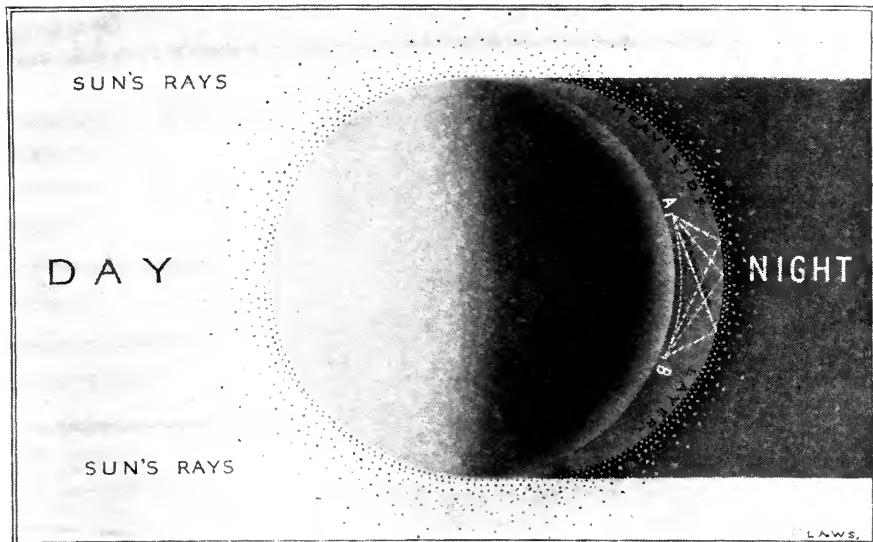

sun shining full on one side, leaving the other in shadow. On the sunny side, what apparently is a swarm of flies is meant to represent electrified particles.

On the dark or night side these particles have recombined near the earth, while many others have risen up to a height and are all huddled up together to form a sort of electrified layer, some 20 or 30 miles above the earth's surface. Daylight diffuses the layer which at night time forms above the earth. The layer was first assumed to exist by Heaviside, and is often known as the "Heaviside Layer."

Near the sunrise or sunset region the diffusion is very great, owing to the sunlight being oblique to the air, and gradually toward the night side the air is cleared of particles, while toward the light side uniform diffusion sets in.

Now see what happens between two stations A and B on the night side. Some of the waves go direct, but many of the waves from A to B hit the layer and are reflected from it. The reflected waves are added to the direct rays, and therefore, as the reflective qualities of the layer vary, so the strength of the signal at B varies. It is as though the layer were a great mirror, and that, as it turns and changes and moves uneasily in its sleep, so the signal is reflected more or less, and so fading occurs.

If this theory is true, certain things could be proved experimentally as follows:—

(1) There should be no fading in the day time, but the signal should be uniformly weaker.

This is generally true.

(2) There should be evidence of rays considerably inclined to the vertical.

In direction-finding work, the general principle

of determining the direction of the incident waves, is to use a frame, the angle of the vertical plane of which can be varied. When the frame is at right angles to the on-coming waves no signals are heard, but this can only be so if the waves are arriving horizontally; any vertical component will affect the frame equally in any position, and no minimum will be found. This actually happens because a simple frame at night gives no reliable bearings due to the presence of the vertical component.

(3) Using a frame which combines so largely the direct and the vertical ray, distortion should occur with speech. This is noticeable more with a frame than with a vertical aerial.

(4) Fading should be more noticeable at great distances from the transmitter than near it. (Obvious from the diagram). This is noticed.

(5) Fading should be more noticeable over land than over sea, owing to the greater attenuation of the direct ray. This has been noticed.

Further than this it is impossible to go, because obviously the whole phenomenon depends so largely upon casual happenings. Undoubtedly, though many of the freak ranges are influenced by casual electrifications forming giant reflectors just in front of the sunset, the extraordinary difference between the power required to drive a signal across the sunset or sunrise band, to that required when this electrified band is removed, is evidence of the justness of the theory, and many of the problems of East and West transmissions are bound up with the same idea.

“Must Be Heard to Be Appreciated”



VAUGHN DE LEATH AS PROGRAM MANAGER
“The Original Radio Girl,” now in charge of the broadcasting programs at WDT, New York, is a composer of songs, a recording artist for the phonograph, possessor of a contralto voice of three-octave range, a pianist, director of an orchestra of sixty pieces, and a recitalist. Hers was one of the first women’s voices to bridge the Atlantic. All who have heard her over the radio will agree that she certainly knows how to put over a song



BILLY JONES AND ERNEST HARE
Two of the most popular fun-makers who ever faced the microphone at WEA. This popular pair had a big ovation at the Tel. & Tel. station in New York at their first appearance, last July, when they caroled about the scarcity of a certain tropical fruit. Considerable experience in recording for the phonograph has taught them how to put over their acts most clearly and effectively for the radio audience



THE SNAPPY UNIVERSITY OF CALIFORNIA ORCHESTRA AT KPO
This sextet has provided, for those tuned in on the Hale Bros. station in Frisco, much sparkling jazz

Who Will Retail Radio?

Is the Phonograph Dealer or the Electrical Dealer Going to Prove Best Qualified to Provide Sales and Service for Broadcast Listeners?

"Is it electrical, Mister Eckhardt?"

No, it's musical, Mister Eltz!"

You have probably heard, and possibly taken part in, discussions relative to the proper agency for distributing radio apparatus to the public. Do you believe that electrical experts will be needed to sell intelligently, and to keep in repair, the sets we shall be using a few years from now? Or do you consider that the broadcast receiver will be primarily a "musical instrument," and therefore best sold by organizations developed for the handling of musical instruments? At any rate, you will be interested to know what a representative of each of these trades has to say on the question.—THE EDITOR.

Radio Sales and Service by the Musical Trade

By W. L. ECKHARDT

President, General Radio Corporation

RADIO as a business is destined to compare favorably with the largest commercial enterprises of all time as soon as experienced business men realize the tremendous possibilities in applying the same principles and policies to the radio business that have been paramount in the development of the automobile and phonograph trades.

RECEIVING SETS CLASSED AS MUSICAL INSTRUMENTS

THE time is rapidly approaching when no home will be considered complete without its radio receiving set, loud speaker and all that goes for satisfactory reception of the broadcasted programs—the important topics of the day, speeches of our great statesmen, and other worth-while features. Therefore, a thing of so great importance in our daily lives requires to be properly merchandised, and should be attended during its original installation by a thorough servicing. It is, therefore, only reasonable to assume that the merchandising of receiving sets will be very readily adopted by that line of trade to which it is akin; and in reviewing the situation carefully it will undoubtedly be appreciated that, first of all, *radio must be classed as a musical instrument*. I do not mean by this that it will take the place of some other musical instrument, but rather that it occupies a position entirely its own, properly located in the musical instrument field, and fortunately so, because in the writer's

opinion no other agency is quite so well qualified to undertake the job as is the music dealer.

PRESENT SITUATION SIMILAR TO EARLY PHONOGRAPH DAYS

IT WAS a long time before the piano and musical trade realized the important part to be played in their businesses that was to come through the medium of the phonograph. In the early days of the phonograph many of the principal musical houses of the country hesitated to take it up, feeling that the phonograph would detract from their piano sales. Back in the late 90's and the days from 1900 to 1905, many of to-day's largest phonograph merchandisers were only luke warm to the possibilities of the phonograph. These same houses have followed somewhat their early impressions in this respect, with reference to the radio receiving set, but on all sides we are now learning of new additions to the radio business in the phonograph and musical trades. These firms are adequately equipped, with suitable show-rooms, demonstration booths, sales organizations and service departments, to install and service the merchandise after installation properly. They make it their business to follow up every sale for a definite period to insure perfect satisfaction on the part of the purchaser.

Prior to 1900, just as to-day in the radio business, it was quite an exception for a talking machine to be sold on the instalment plan; but by 1904 it was generally accepted by all leading merchants that the sale of phono-

graphs would be substantially increased by offering them on time payments, or on a club plan. This is bound to follow at a very early date in the radio business; as a matter of fact, it is being done at the present time to a modest extent by a number of enterprising merchants.

Of course it is needless to state that just as the phonograph business was not confined exclusively to the phonograph and the musical trades, but was merchandised frequently through the sporting goods shop, the hardware shop, gas and electrical companies, jewelers and the like, so radio will be handled by a miscellaneous line of trades; but in the course of a very short time I am of the opinion that we shall see the bulk of the radio trade, that is with reference especially to the completed sets, handled through the phonograph and musical trades.



SELLING OF RADIO NOT YET WELL DEVELOPED

IT IS only natural that in view of a quarter of a century of experience in the phonograph and musical trades, I am partial to this particular field. But I am certain that an unbiased observer acquainted with the situation would be convinced that as soon as experienced merchandisers take the time to survey the radio business it will require more than the fullest capacity of all radio manufacturers in the country to cope with the demand and requirements. I truly do not feel that the radio business has been seriously taken into hand up to the present time. There are very few firms who are in a position to do it full justice; and if other lines of trade had been conducted in the way that the radio business has been conducted during its early days, they would never have had the success of such trades as the automobile, motion-picture, and phonograph industries.

During the past season it has been diffi-

cult for many interested buyers to locate a responsible merchant through whom they could secure guaranteed radio apparatus, although a great number of little merchants profess to be radio dealers and in the majority of cases confined their efforts and display to an assortment of miscellaneous parts for the "build-your-own" customers. This was undoubtedly prompted by the shortage of completed sets during the early days, and by the great interest of the younger generation, who were educated to build their own because of the extraordinary emphasis laid upon the great difference between the cost of the completed set and the cost of the parts required to make a similar set at home. This feature of the radio business, however, is rapidly passing, in the writer's opinion, and I do

not under any circumstances recommend this class of merchandising for the musical industries. It is distinctly a separate business and may be handled by such wide variety of merchants, embracing everything from the junk dealer, hardware store, electrical store, electrical contractor, to the department store, but in no case does this feature of the business belong in the musical trade.

That the radio business will come into its own, and be embraced principally by the musical and phonograph trade during the coming winter, I am firmly convinced, although a number of the better electrical firms which have all the elements required to merchandize and service radio properly, will also secure their share of the trade. In our organization we have developed a complete service training school, in charge of competent engineers, and we recommend to all merchants that they send their salesmen and service department men into our laboratory, without cost, to secure the necessary training for the proper exploitation, sale and service of radio receiving sets.

What Would You Like to Have in RADIO BROADCAST?

The editors would be pleased to hear from readers of the magazine on the following (or other) topics:

1. *The kind of article, or diagram, or explanation, or improvement you would like to see in RADIO BROADCAST.*
2. *What has interested you most, and what least, in the numbers you have read so far*

Why the Electrical Dealer is the Proper Outlet for Radio

By GEORGE J. ELTZ, JR.

Radio Sales Manager, Manhattan Electrical Supply Co., Inc.

SINCE the introduction of radio broadcasting in 1921, radio material has been sold on a number of different merchandising plans through a great many different sources. Some of the plans followed and some of the outlets through which radio material was sold, have been quite satisfactory; but in general the most satisfactory outlet from a standpoint of both the manufacturer and the public, has been that which was used prior to broadcasting—namely, the electrical dealer.

HOW SETS ARE NOW SOLD AND WHY

THE radio business of to-day may be quite clearly divided into two parts:

1. Business on complete sets which are:
 - (a) Sold complete with all the necessary equipment to the customer who does the installation work himself.
 - (b) Radio sets which are installed complete in every detail in the home of the customer by the party making the sale.
2. Parts business:
 - (a) Sale of complete sets of parts to a customer, with detailed instructions by the party making the sale, on the manner in which they are to be connected.
 - (b) Sale of parts to customers who are familiar with the manner in which they are to be used.

The radio business of the United States is now one of the big industries of the country, from the point of view of volume as well as of public interest. Strange as it may seem, of all the other large industries in the United States, radio is probably the only industry which is conducted along the lines outlined above. There are a number of good reasons why this should be the case. Radio as an art has been familiar to a small number of people for the past twenty years. Previous to radio broadcasting there were approximately 150,000 amateurs in the United States who were intensely interested in radio. It is safe to say that every one of these amateurs had at some time or other manufactured a radio set. There were several reasons for this:

1. The amateur could not always procure a receiving set completely assembled which suited his own particular needs.
2. It was practically impossible for the amateur to purchase a complete transmitting set, a side of the radio industry in which he was intensely interested.
3. The prices of both the receiving and transmitting sets were exceedingly high and the average amateur could not afford them.
4. The patent situation controlling the manufacture of both transmitting and receiving sets was as involved then as it is at present and complete transmitting and receiving sets, even when purchased, frequently lacked one or two essential characteristics which it was necessary for the amateur to add in order to obtain best operation.

Due to the above causes, the amateur became familiar with the construction of radio apparatus. Manufacturers were quick to realize this, and produced a complete assortment of parts which permitted the easy construction of the complete sets used by the amateur.

WHY "BUILDING YOUR OWN" IS SO POPULAR

WHEN broadcasting was started, there was, consequently, a more or less complete assortment of radio parts available, and what is more important there were these 150,000 amateurs, all familiar with radio construction and all more or less prejudiced in favor of the purchase of parts in the construction of radio sets instead of the purchase of complete instruments. That these amateurs have been a decided factor in the present division of the radio industry cannot be denied. The propaganda in favor of the construction of sets from parts spread by these amateurs and the fact that a great shortage of complete receiving sets existed when radio broadcasting first started, unquestionably accounts in a large measure for the great use of parts by the general public. That this use of parts will continue for some time (and, in fact, that it may always continue) is borne out by the ratio of parts sales to complete set sales, and the immediate interest of the public in any new part which is placed on the market.

THERE ARE NO PHONOGRAPH "AMATEURS"

THAT the great volume of parts sold is a peculiar condition of the radio industry is evident from a consideration of a more or less parallel line, the talking-machine business. Of all the thousands of talking machines in use, probably less than a fraction of 1 per cent. have been constructed by the users. This is in spite of the fact that talking machine parts are available in almost as great profusion as are radio parts. Complete talking machines can be constructed for considerably less money than complete radio sets and with a much greater certainty of satisfactory operation. As far as can be learned, there has never been a class of amateur phonograph constructors, and in their absence information regarding the construction of phonographs was not general. As a result there was never the demand for parts which exists in the radio industry and the sales of phonographs were confined almost exclusively to complete instruments.

A consideration of the above facts is necessary in order to obtain a true picture of the radio situation of to-day and in all probability of the radio situation of the future. Unquestionably from the angle of the public, manufacturer and dealer, it would be far better to have radio sales confined entirely to complete sets. There are two good reasons for this:

1. If the demand was confined to complete sets, the production of complete sets would increase, with a consequent decrease in manufacturing cost and cost to the consumer.
2. The public would be assured of obtaining a receiving set which would give satisfaction—which is not always the case when the unskilled amateur attempts to construct his own set from parts.

Be that as it may, the facts of the case are that radio material will always be purchased in two clearly defined ways—as complete sets, and as parts for assembly.

DIFFERENCES BETWEEN THE RECEIVING SET AND THE PHONOGRAPH

WITH these facts before us, let us see what is the best method by which the apparatus can be placed before the public. No matter from what angle radio is viewed, whether it be complete sets or parts, radio apparatus is apparatus of a *technical* nature. There are so many different factors entering

into the operation of a radio set, that to compare it with a phonograph would be foolish. A phonograph is a purely mechanical device which has been simplified so that it contains but few parts. It can be easily set into operation, and once operating will give practically no trouble. The phonograph will operate equally well regardless of location. You know what you can expect of it, anywhere, anytime. The sale of a phonograph is consequently a pure selling job, where the appeal can be made purely on a price or quality basis and positive assurance given the customer that the machine will operate properly. The sale of a radio set is essentially different.

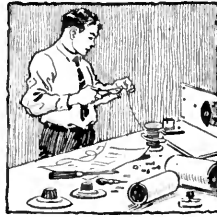

1. The customer has to be sold the idea of radio, its advantages, and why he should supplement his phonograph with a radio set.
2. The customer cannot be positively assured that the radio set will work perfectly in the location in which he desires to have it installed. The installation of the set is frequently requested by the customer, and a great many times the sale cannot be made unless installation can be undertaken by the dealer.
3. The installation of a radio set, while it has been considerably simplified since the advent of radio broadcasting, still is infinitely more complicated than the installation of a phonograph. To a person familiar with the installation it is a comparatively simple problem; but to be successful a dealer requires a more or less trained personnel.
4. Radio sets require a certain amount of maintenance which the purchaser naturally looks for through the source from which he purchases the radio set. This service, it is true, may be charged for; but again this requires trained workers.

With these facts in mind, let us consider which class of merchant serving the public at the present time is best fitted to carry on the sale of radio material. It has been clearly demonstrated that the accepted method of distribution, by means of distributors and jobbers, may be successfully applied to radio material. The following channels through which purchases may be made by the user are available:

1. Hardware Dealers
2. Department Stores
3. Phonograph Dealers
4. Electrical Dealers
5. Special Radio Stores

Consider separately the five different sales channels listed above:

1. *Hardware Dealers*

Hardware Dealers have never taken very keenly to the sale of electrical equipment. The merchandise they sell and the class of trade which their establishments attract, are concerned more with mechanical than electrical contrivances, although some of the larger hardware dealers have established electrical departments and have been extremely successful in the sale of electrical equipment.

2. *Department Stores*

Department stores can profitably handle radio material in a large volume if they have already established an electrical department in charge of a trained personnel. In this particular regard, they are more or less similar to hardware dealers who establish a special electrical department.

3. *Phonograph Dealers*

Phonograph dealers, it would appear on first thought, should be a good outlet for radio apparatus. If, however, the problem is a little further analyzed, the facts will not bear out this contention. Speaking of the average phonograph store—not the large establishment, where the installation of a special radio department would be possible and probably practical—the personnel employed by phonograph dealers is not trained in the particular way necessary for the sale of radio equipment. This is true even if the sale of radio equipment is confined entirely to complete sets. The average phonograph dealer or phonograph salesman is in every sense of the word a salesman. He is quick to answer questions which may be put to him on the operation of the phonograph; but generally he is not in a position to discuss the technical phases of even the phonograph's construction and operation. If a phonograph dealer is to sell radio equipment, even complete sets, it will be necessary for him to secure the services of a more or less trained selling force who are capable of answering fairly technical questions; and it will be necessary for him to establish a department to install properly the radio sets which are sold, and to maintain radio sets which have been placed in operation. In selling complete sets the problem is of course much simpler than when selling parts. The sale of parts requires the service of a man who is fully familiar in every particular with radio circuits and radio construction work. Such a man, as a general rule will not be of particular service in the sale of phonograph equipment. The result is that the phonograph dealer must establish a complete radio department. This is an additional expense which will naturally reflect itself either in an increased price of material to customers or in decreased profit.

4-5. *Electrical Dealers and Special Radio Stores*

Electrical dealers and special radio stores at the

present stage of the radio industry cannot perhaps be properly grouped together when due regard is taken of all the facts. It will only be a question of a short while, however, before the special radio store will handle, in addition to radio equipment, other profitable lines of electrical merchandise. Practically everyone is a user of electrical equipment to some extent. It is but natural for the public to attempt to purchase some of this electrical equipment at the same place where they obtain their radio supplies and equipment. The progressive owner of a special radio store is bound to recognize this demand and will unquestionably, as has been the case in a great many instances, install a special department in which the more profitable lines of electrical merchandise, other than radio, are sold. It is, therefore, correct to class electrical dealers and special radio stores in the same category. The statements which apply to the electrical dealer, then, apply equally well to the special radio stores.

Let us consider what qualifications the electrical dealer has which would permit him to sell radio equipment readily:

1. *Personnel*

The salesman in the average electrical dealer's store has been trained to think along electrical lines and to explain to the public the operation of electrical devices. By familiarizing himself with radio, therefore, he can talk in a manner which the public understands. The sale of radio material by an electrical dealer does not require the installation of special salesmen, merely the training of those already employed.

2. *Installation and Maintenance Factors*

The electrical dealer has been accustomed to maintaining and installing electrical apparatus in the homes of his customers. The same personnel which is necessary for this work is in a position to undertake readily the installation and maintenance of radio equipment.

For the sale of parts the electrical dealer is much better qualified than any of the other merchants listed above. The arrangement of his electrical stock is quite similar to the arrangement which will be necessary to make when radio parts are handled. He is familiar with the sale of small items from past experience and is accustomed to carrying in stock a varied assortment of parts. The personnel in the electrical dealer's store through their own knowledge of electrical devices can more easily adapt themselves to the problems presented by radio, if, indeed, they are not already familiar with them.

Of prime importance, and the greatest ar-





THE RADIO DEPARTMENT OF A LARGE ELECTRICAL SUPPLY HOUSE

Here the experimenter and broadcast fan can obtain about anything they want from complete sets to binding posts

gument in favor of the electrical dealer handling radio equipment is that outside of the investment required for a stock of radio equipment, the electrical dealer is required to go to almost no additional expense. The investment in radio stock for establishments of the same size will be approximately the same for any of the merchants enumerated above. In the case of all of them with the exception of the electrical dealer, a separate department must be installed, or if it is already installed must be slightly modified and a special arrangement made to carry out the installation and maintenance work properly. An increase in operating expense, whether it be brought about through the addition of new personnel or through the addition of a special department must reflect itself directly in the profits of the dealer. This increase in operating expense will eventually reflect itself in the list price of the apparatus sold. If the profits of the dealer are not sufficient to make radio a paying line he will compel the manufacturer to increase his profits to him. The manufacturer in turn will have to forego

some of his profit or else increase the price to the consumer. The price of radio apparatus at the present time is high. A further increase in list price would certainly cause a decrease in the volume of sales. That channel of distribution which places the apparatus in the hands of the consumer at the lowest list price with a fair profit to all parties concerned in the transaction is the best channel through which to merchandise radio.

Thus, unquestionably, at the present time the electrical dealer is the best fitted to handle radio material, and through this channel practically all the radio equipment which has been sold over the past two years has been distributed. The progressive radio dealer has in the radio line a potential business which is greater than any other line in the electrical industry. Radio dealers have been quick to realize this and although other methods of distribution will unquestionably be attempted, the electrical dealer has taken foremost rank in the distribution of radio material and bids fair to hold his place.

A Well-Made Place for a Well-Made Set

For Those Who Can Spare One of Their Book-Case Sections, This Manner of Installing the Receiving Set Is Worth Considering

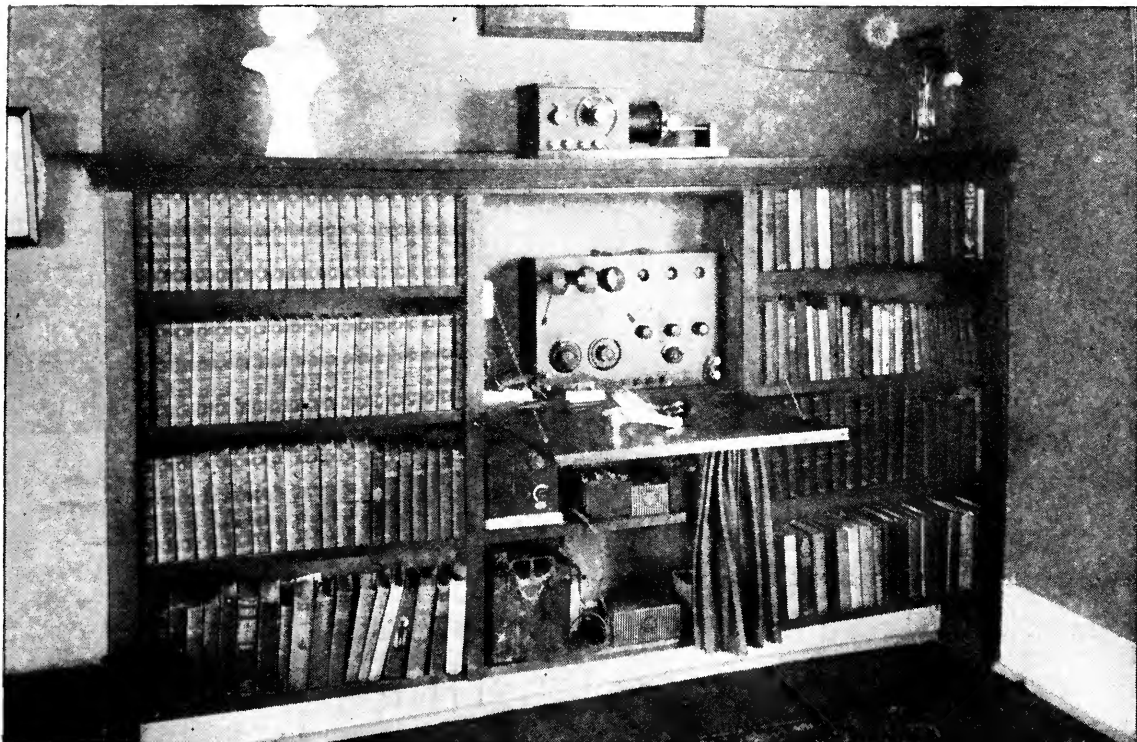

NOW YOU SEE IT AND NOW YOU DON'T

The fan who begins with a neat set each evening and ends with a set *plus* wire, parts, junk, tools, etc. is advised against this scheme

AN UNUSUAL feature of the receiving outfit constructed by Mr. John Showalter, of Wabash, Indiana, is the place in which it is kept. Only one shelf in the center section of a three-section bookcase had to be removed in order to install the complete three-tube receiver, storage battery, charger, and B batteries. The simplicity of the arrangement is what will appeal to many enthusiasts. You merely close up the desk board, draw across the curtain, and you have a library again instead of a radio corner.

Mr. Showalter has heard over 130 different broadcasting stations with the three-circuit honeycomb coil outfit shown in the accompanying illustration. In the winter, he has often been able to pick up KHJ, Los Angeles, 1800 miles from his home.

His is not the apparatus of a broadcast fan, however; for he says that he "hates to see the amateur telegrapher fade into oblivion as the so-called broadcasting craze springs into more and more prominence."

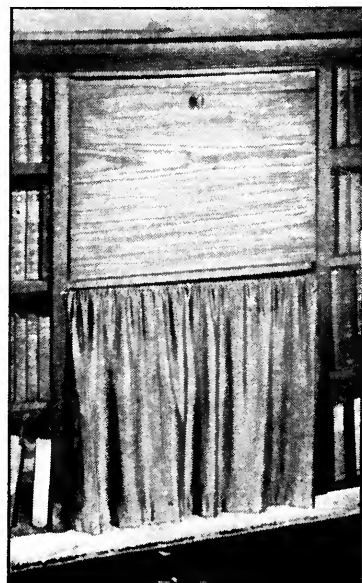

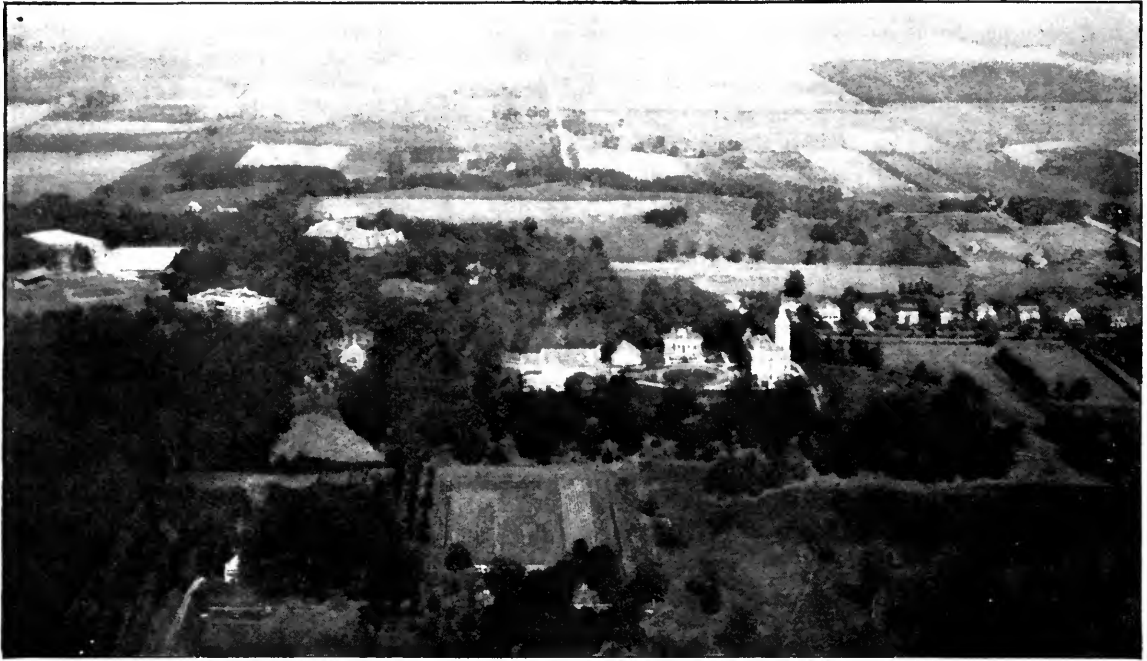

AIRPLANE VIEW OF ST. OLAF COLLEGE, NORTHFIELD, MINN.

From the point at which the picture was taken, the ground of course seems flattened out; but the college is located on Manitou Heights, a considerable rise above the surrounding country

What a College Can Do in Broadcasting

The Achievements of St. Olaf College with Station WCAL, Northfield, Minnesota. Talent and Friends, the Two Natural Advantages Which Any College Has in Operating a Broadcasting Station

By FRANKLIN CLEMENT

OCCASIONALLY a radio station, like some persons, is born with a silver spoon in its mouth, and is able to weather successfully vicissitudes that have destroyed other stations less fortunately situated. A table in *RADIO BROADCAST* for March, 1923, showed that at that time broadcasting stations operated by educational institutions led the field in apparent permanence. Perhaps the spoon has helped.

WCAL, operated by the department of physics at St. Olaf College, Northfield, Minnesota, was one of the earliest stations in Minnesota, and is now the oldest continuously operated

station in the state. St. Olaf is a standard liberal arts college that had during the past year an attendance of 948 students. It is owned and controlled by a synod of the Lutheran faith, the Norwegian Lutheran Church of America. Its students come for the most part from Minnesota and adjoining states: Wisconsin, Iowa, and the Dakotas, but there are not a few from more distant states and countries, including representatives from Maine, Washington, California, Texas, and several provinces of Canada.

The St. Olaf College station, and every college station, has at least two distinct advantages over those operated for more commercial

purposes: an unfailing program supply, and an established clientele.

PLENTY OF MUSICAL TALENT

EVERY standard college has in its students and faculty a wealth of musical, dramatic, forensic, and athletic talent, by the very nature of college requirements and conditions. St. Olaf is particularly fortunate in having at the head of its school of music Dr. F. Melius Christiansen, who has produced under his direction the St. Olaf Lutheran Choir, an organization with an international reputation for choral singing. When the choir, long recognized in Minnesota as of an unusual character, first invaded the East in 1920, it received such extravagant praise as to make the tour a complete triumph, and gained from the best of the nation's critics the title, "the world's supreme choir." Coming into prominence almost simultaneously with the popular *Main Street* of Sinclair Lewis, it was hailed as "the vindicator of Main Street," and a Brooklyn critic wrote that the choir had "proved that Gopher Prairie and its environs are dispensers, not despisers of culture." The reputation thus founded has been more securely established in succeeding years.

Naturally, then, St. Olaf College is the gathering-place for a large number of capable student musicians, and from the membership of the choir numerous artists are selected for the programs broadcasted from WCAL. To the

thousands of persons throughout the country who have heard the choir, the radio programs are of peculiar pleasure even aside from their merit, because they have seen and heard the singers in person.

But things musical at the college are not limited to the choir. There is an excellent concert band of forty pieces, developed by Dr. Christiansen, and now under the direction of J. Arndt Bergh. The band has undertaken extensive tours, including one to the Pacific coast last spring, and has been enthusiastically received. Its members have contributed often to the success of WCAL concerts. There is also a college orchestra as well as numerous smaller orchestras, quartets, and other groups of entertainers, composed and managed by students.

At a college of liberal arts, with music one of the arts, a high standard is to be expected. Then, also, there is in all college programs an appealing youthfulness which is one of their greatest charms. It is the amateur instead of the professional. While the same perfection of production may be present, there is added the ingenuous enthusiasm of youth in its own performance.

But music forms only a part of the programs any college station is in position to offer. Other forms of entertainment are equally welcome. Within the short space of three years the English department at St. Olaf has built an innovation into a tradition, and now



THE 1922-23 ST. OLAF LUTHERAN CHOIR

This organization, developed by Dr. F. Melius Christiansen, has excited the admiration of the nation's best critics. It has given many recitals at WCAL.

the annual production of a Shakespearean play is of such moment that visitors are attracted from all over the state. In November, 1922, the WCAL officials decided to try what was at that time an experiment, the broadcasting of a play, and the resulting radio production of Shakespeare's "As You Like It" was one of the first broadcasts of a play in history. The experiment was successful, enormously so, and a repetition was demanded. The resulting letters showed how genuinely appreciative the radio listeners were. High school teachers of English who could not hope to show their pupils a stage presentation of a Shakespearean drama told how the evening had helped them in their work; excited high school pupils wrote of their own pleasure, and Shakespearean admirers throughout the United States and Canada expressed their thanks.

Colleges can also provide speakers. Informative lectures on popular subjects of politics or economics were early introduced in WCAL programs, and during the past year radio extension courses were offered in the departments of biology, chemistry, economics, education, and philosophy, by department heads. Responses indicated that the lectures were welcomed in innumerable homes.

Sermons, too, have been a part of the college radio programs. College chapel services, broadcasted direct from Hoyme Memorial Chapel at St. Olaf, have been of special interest to the homes represented by sons or daughters or friends at the institution. Occasional speakers

visiting the college have found their audience greatly increased by the marvelous development of broadcasting. Such a one was Dr. Paul Harrison of Arabia, a medical missionary with wide experience, who, when visiting St. Olaf was privileged for the first time to address unseen radio listeners. Of interest also to these listeners, judging by reports, was a radio debate on the question, "Resolved, that the United States should enter the League of Nations," when the two St. Olaf teams which had represented their college victoriously in six intercollegiate contests, were so well matched that the decision of the listeners who took the trouble to mail their votes was an exact tie!

And athletics? Minnesota fans follow with eager interest the major sports of the eight colleges composing the Minnesota Intercollegiate Athletic Conference: Carleton, Concordia, Gustavus Adolphus, Hamline, Macalester, St. John's, St. Olaf, and St. Thomas. Whenever a contest is held in Northfield—and both Carleton and St. Olaf are in Northfield—WCAL broadcasts the result of the contest, and has frequently sent out, direct from the floor or the field, a play-by-play account of a basketball game or gridiron conflict. This was made possible by the construction of a small portable studio which could be set up on the sidelines. The athletic news and news of other activities finds favor with many listeners not otherwise given to the habit of head-phones.

That is one of the tremendous advantages a college has in broadcasting—the ability to pre-



PLAYERS IN "AS YOU LIKE IT"

Miss Ruth Vaaler, of Fosston, Minn., and Gonard Felland of Stoughton, Wis., as Rosalind and Jacques in the production of Shakespeare's comedy, which was sent out by radio from the St. Olaf station



sent from its own talent attractively varied programs of music or lectures, readings or news accounts. It has in its own house the material which many a metropolitan station must beg, borrow, or buy.

A NATURAL ADVANTAGE OF A COLLEGE STATION

COLLEGE stations have listeners. So has any station, of course. But the college station *begins* with a long list of loyal supporters, and has that list to build upon. The list is made up of alumni and former students, of parents and friends of students, and of friends of these friends. The name of the institution is a magic word which, like a gracious introduction, puts host and guest at ease. The station's programs at least enter these homes auspiciously, and if the programs are good they will be ever welcome.

St. Olaf College has a normally large circle of such friends. Because of its nature, an institution supported by a church body with nearly 300,000 adult members, it can count all these church members as persons actively interested in the college



CHEERS BY RADIO

Sam Groth, St. Olaf cheer leader, under whose direction college cheers have been relayed by WCAL



MISS RAGNA OTTERSEN

Whose beautiful soprano voice has given pleasure to thousands of WCAL's listeners. Miss Ottersen was a senior at St. Olaf College during the past year and a member of the Lutheran Choir there

and in its work. It has, too, its hundreds of alumni and former students, whose interest and friendliness is maintained by this modern marvel.

Long after radio broadcasting became established and even commonplace, the newspapers continued to print human-interest items telling how a mother in Louisville heard her daughter singing in Atlanta, of how a girl in Minneapolis spoke by radiophone to her invalid father in Kansas, and so on. At a college station such items could not be made news, for they are not news. They happen daily. Hardly a program but represents a half dozen communities in nearly as many states, each listening eagerly to the voice of its distant citizen. Each week the letters go home: "I am to sing by radio Thursday evening," or "I'll be playing a cornet solo Saturday night," and the telegrams come back: "We heard you singing to-night" and "It sounded as if you were here."

Perhaps this article has failed to discover the real reason for the permanence of college stations—it may lie in the possibilities for research and experiment which a college offers, or it may lie elsewhere. But at any rate it seems fairly certain that these two advantages the college station has: it can furnish a variety of entertainment and instruction, and it is born with friends. Possibly before long, wealthy persons will endow college radio stations as memorials, just as wealthy persons have established memorial halls and memorial scholarships. For the service they render, college broadcasting stations receive nothing in tangible revenue; but they seek nothing. Theirs is distinguished service.

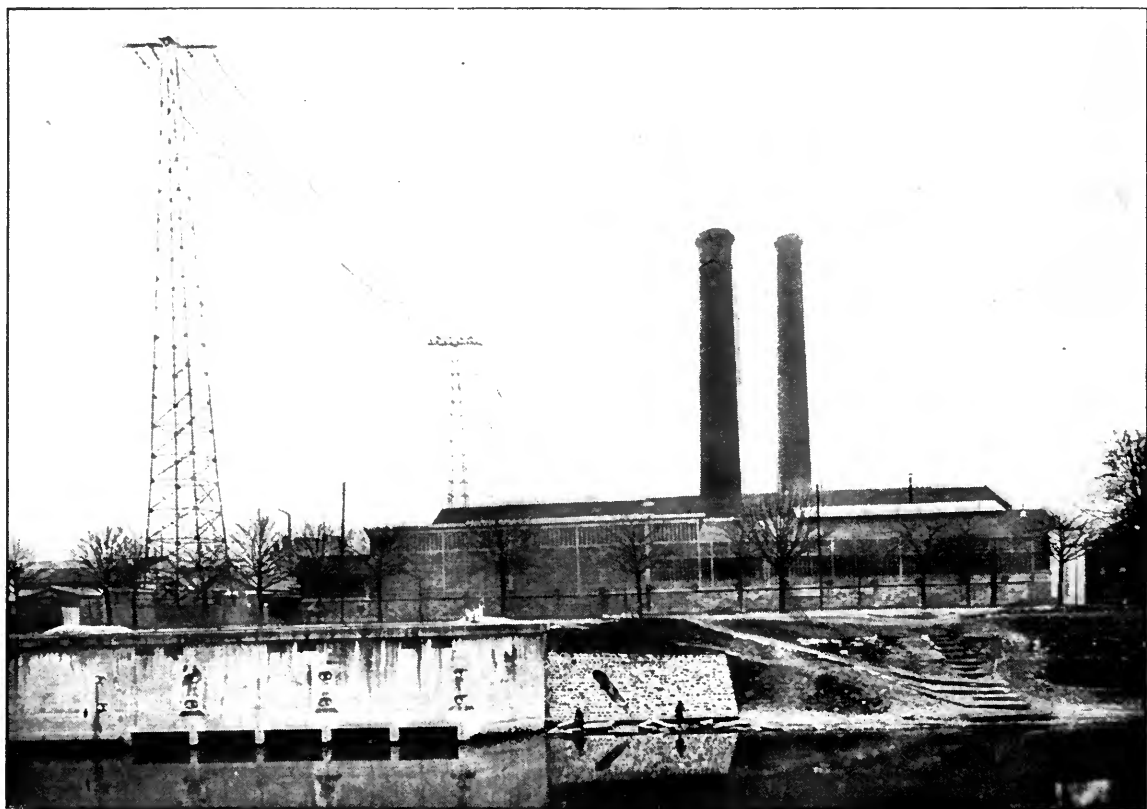

VIEW OF THE "RADIOLA" AERIAL, TAKEN FROM ACROSS THE SEINE
Showing the factory of the Société Française Radioélectrique

A Voice from the Banks of the Seine

A Description of Station "Radiola" in Paris, One of the Largest of the Continental Broadcasting Stations

By FREDERIC M. DELANO, JR.

ON THE banks of the Seine River, in the suburbs of Levallois-Perret well outside the walls of Paris, is a modern plant, whose engineers work long and hard to develop better methods of radio communication, and whose nightly broadcasts bring pleasure to thousands in France, England, Spain, Italy, Belgium, and perhaps even desolate Russia.

In 1922, when the radio craze was gathering momentum in the United States, and there were more than 400 broadcasting stations in operation, there was not a single broadcasting

plant worthy of the name in France. It is true that as early as November 26, 1921, a popular radio concert was given on the occasion of the Ampere Centenary. A similar affair was staged in June 1921, at a meeting of the Society of Civil Engineers, and another one at the Théâtre des Champs Élysées, in December of the same year. But, it wasn't until the 6th of November, 1922, that radio concerts were sent out on a regular schedule.

The first attempt at radio broadcasting on a daily schedule was made by the Société Française Radioélectrique, and came at a time when

the big broadcasting stations throughout the United States were known by name and call letters to thousands of radio fans. From that time on, the "Radiola" concerts have been exceedingly popular with the newly initiated French radio enthusiasts. In France, you do not refer to broadcasting stations by their calls. They have names, such as "Radiola." Besides, there are only a handful of them, so there is not much trouble in telling them apart—and not much interference! The first transmissions took place on a wavelength of 1850 meters, but owing to interference with the military authorities, this wavelength was later reduced to 1760 meters. It has an advantage over the broadcasting on the lower wavelengths which takes place in the United States, in that there is little or no interference from commercial or amateur sources. Whether this wavelength will be permanent or not is a matter of speculation, for broadcasting is not as yet established on a solid basis in France.

The "Radiola" broadcasting station is even yet a decidedly experimental one, according to the statements made by the men in charge, who

are not willing to give out much information about it until it shall have been proven a permanent installation. The first set with which they worked stands on one side of the room, neatly caged in, to be used only as an emergency or substitute set, in case the second and newer one, on the other side of the room, should get out of order. A third transmitter is being constructed, destined primarily for experimental work, but which may eventually be the permanent one. Furthermore, as soon as possible the whole broadcasting station is to be moved to another and more open location away from the handicap which they are at present experiencing in the many steel and iron structures surrounding them.

The station arrangement is more or less on the same order as many of the American stations: the studio is in the heart of Paris (79, Boulevard Haussmann), far away from the rest of the transmitting apparatus. The singers, musicians, and speakers in the studio therefore talk through the microphone to the Levallois plant over a wire circuit.

The studio director, M. Charpentier, himself

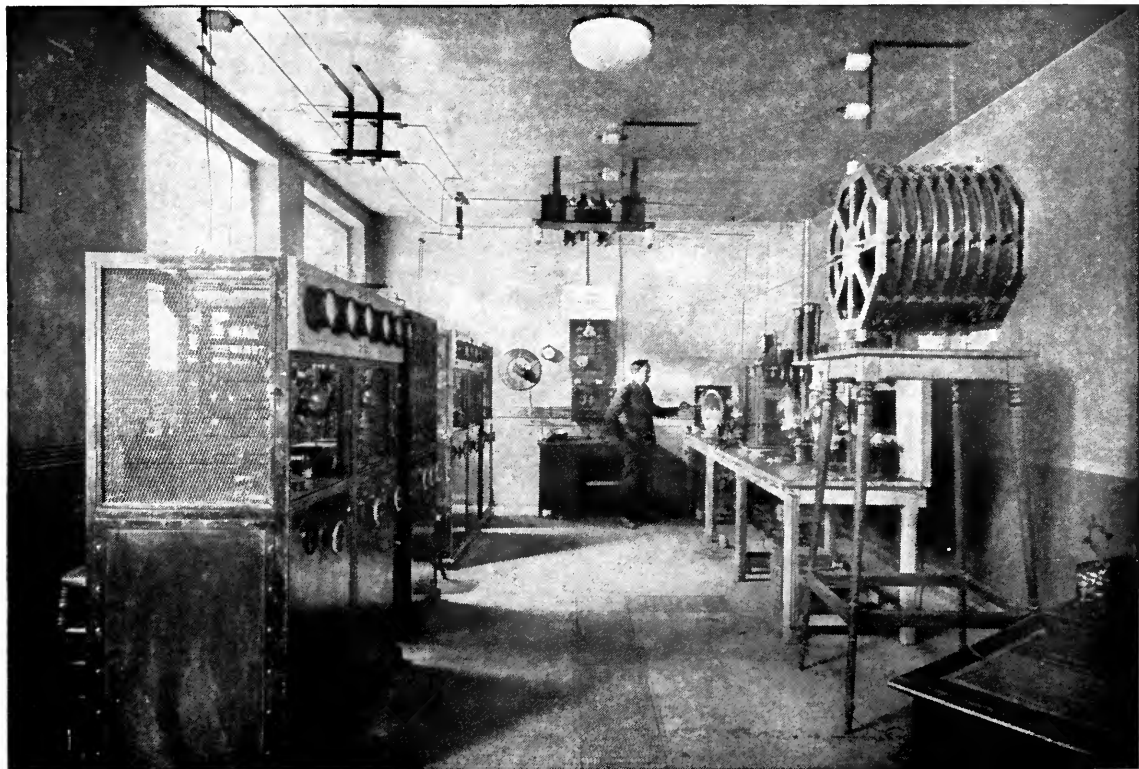

THE BROADCASTING STATION AT LEVALLOIS-PERRET

The set used at present is seen at the right; on the left is the secondary, or emergency apparatus



HIS HIGHNESS, THE MAHARAJAH OF KAPURTHALA
At the "Radiola" studio, 79 Boulevard Haussmann, Paris

a well-known composer and musician, takes particular interest in devising novel and interesting programs for his invisible audience. He often gets prominent persons to deliver short lectures before his microphone, and shows his guests an autograph book which bears the signatures of Mlle. Suzanne Lenglen, the tennis champion; General Garibaldi, the Italian; Cecile Sorel, the famous French actress who recently visited the United States; the Serbian Ambassador, and many others. The only trouble with the studio, according to Monsieur Charpentier, is that the ceiling is slightly low for the best sound effects. This, however, would be difficult to rectify in the present location as it is situated in the basement of an office building.

Each of the two stations out in Levallois-Perret can be cut in on the concert from the city by means of a switch at one end of the room, whence the music goes to the broadcasting apparatus and leaps out from the antenna to the ears of all who care to adjust their sets and listen-in.

A GROUP OF FRENCH CONCERT ARTISTS AT THE "AUDITORIUM RADIOLA"
This station has not been restricted to French or even Continental talent. People of international prominence from all parts of the globe have from time to time contributed to its programs



How to Eliminate Interference with a Home-Made Wave-Trap

Complete Instructions for Building an Inductive Wave-Trap and Using It with Your Present Receiver to Cut Out Stations that Ordinarily Cause You Interference

By A. J. HAYNES, Jr.

Vice-President, Haynes-Griffin Radio Service, Inc.

THE increase in the number of broadcasting stations within the last year has created a condition of interference in many of the larger centers, such as New York and Chicago, which is becoming increasingly more troublesome. Owners of radio sets which are generally regarded as extremely selective are finding that near-by or very powerful stations are exercising a blanketing effect upon their receiving apparatus, so that it is next to impossible to hear other stations clearly and distinctly.

Nothing is more irritating to the DX fan who may live within a few city blocks of a powerful broadcasting station than to spend several minutes trying to bring up a very weak station to the point of proper audibility, only to have his powerful neighbor break in and completely blanket his tuning adjustments. As a certain gentleman of color, who was attempting reception under such conditions, once declared, "Intuference is de one thing we ain't got nothin' else but!"

The radio enthusiast who is fortunate enough to live 100 or so miles from the nearest broad-casting station is not much troubled by interference. At this distance, the natural selectivity of his receiving set is sufficient in itself to separate the various broadcasting stations, and his opportunity of making a selection for several stations is very much better than that of his less fortunate brother who may live in the same city with some powerful station. His opportunity for long distance reception is also considerably better

than is that of the man located close to the broadcasting station, because he does not first have the problem of eliminating the local station, which, because of its proximity, comes in with such power as to preclude the possibility of critical tuning.

Hence this article is written primarily for the radio user who is located close to one or more broadcasting stations. The fan who lives at a good distance from any station at all will not be interested particularly in securing an adjunct to his present receiving set that will help to eliminate interference. If the latter is unable to obtain fair selectivity, he should give thought to the improvement of his receiver itself, or if necessary, replace it with a better one.

THE NEED FOR A WAVE-TRAP

PROBABLY nowhere in the world is the interference between broadcasting stations so acute as in New York City. At the present time, there are eight active broadcasting sta-

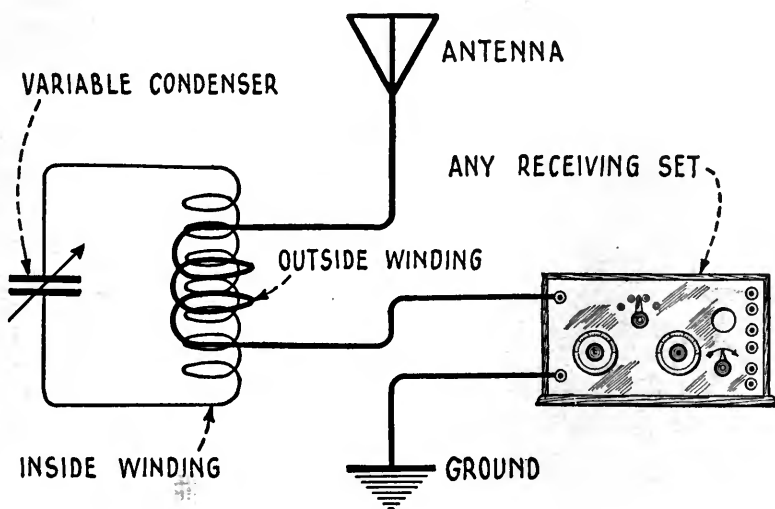

FIG. 1

Schematic diagram of the inductive wave-trap in circuit with the receiving set

tions within the Metropolitan area, with promises of even more in the near future. In the spring of this year, when the new schedule of wavelengths was established, and some of the more important stations were relocated, radio engineers were importuned on every hand for some means by which these various stations could be better separated. "Distance fans" wanted to be able to cut out the local stations entirely so as to reach out to programs from stations in the West and South. This had become an impossibility for those located in the center of the City, very near to stations WJZ and WEA. In fact, in many instances it was found, depending somewhat upon the location of the receiving set, that whenever these powerful stations started to operate, it was practically impossible to eliminate either one or both of them and hear any other station at all clearly.

I had been conducting experiments for some time upon the inductive wave-trap described in this article as offering the most practical solution to the problem; and the acuteness of the situation made it imperative that something be done at once.

SOME INTERFERENCE CANNOT BE ELIMINATED

IN CONSIDERING interference between broadcasting stations, it is very necessary to know that which can properly be eliminated, and that for which there is, to date, no known remedy. The most common form of inter-

ference which cannot be effectually eliminated is that caused by two stations which are operating on identically the same wavelength bands. This will produce a steady heterodyne note, or whistle, in the headphones whenever this particular wavelength is tuned in. This type of interference can be distinguished by the fact that it can be heard without the receiving set oscillating (contrary to the usual heterodyne beat note), and does not change pitch as the receiver is adjusted. This interference is, of course, the fault of the transmitting stations, and they should be notified of the fact that they are on each other's wavelengths.

ADVANTAGES OF THE INDUCTIVE WAVE-TRAP

WAVE-TRAPS have been used more or less successfully for years, generally by commercial operators on telegraph signals and later by broadcast listeners. The wave-trap which was in use until somewhat recently, however, was not altogether efficient. It filled the main purpose of trapping out the interfering signal, but at the same time, frequently reduced the signal strength of the station which the operator wished to hear so seriously as to make the remedy of little practical use.

The inductive wave-trap which we are considering is a great improvement over its predecessor, which, in more cases than not, consisted simply of a single coil and variable condenser in series with the antenna. The idea itself is not a new one, although it has never had any great commercial application to radio-telephone reception. Well-built inductive wave-traps overcome the defect which I have mentioned and operate with much greater efficiency on the broadcasting wavelengths than the old style wave-trap. In fact, in many cases where the interfering station is a powerful one, the weak station received through it will be materially strengthened when the wave-trap is set to cut out the former.

HOW TO BUILD YOUR OWN WAVE-TRAP

THE inductive type of wave-trap is particularly useful when used as a rejector circuit—that is, in series with the antenna between the lead-in and the set. It consists of a coil of approximately 45 turns of medium-size copper wire, generally wound on a cylindrical form about $3\frac{1}{2}$ inches in diameter, with a variable condenser of about .0005 mfd. capacity connected across it, the combination forming an oscillating circuit. A second coil of about 10 turns is wound on top of the first winding so

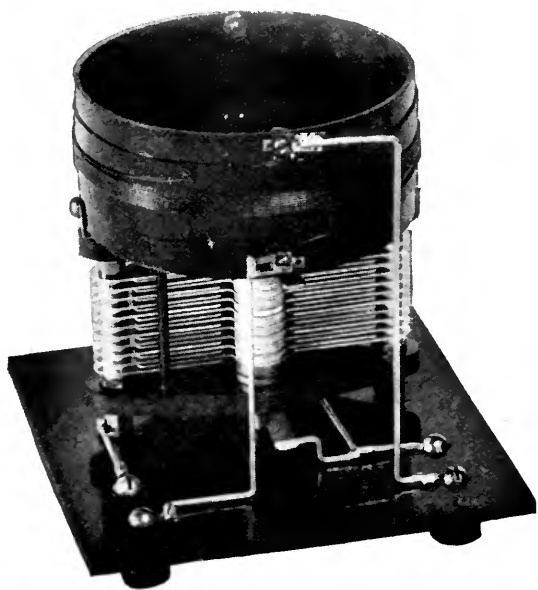

FIG. 2

How the unit looks when assembled

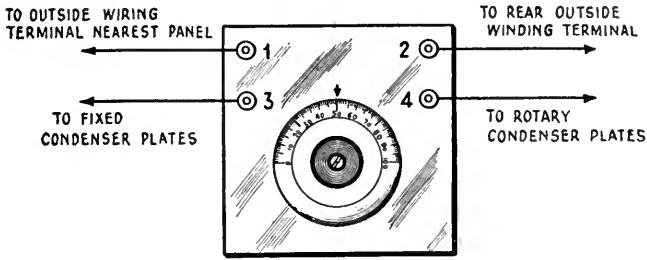

FIG. 3

Showing the panel of the wave-trap and connections that are made to the four binding posts from the wave-trap itself. These four connections are also shown on back of the panel in Fig. 2

as to be in inductive relation to it, but insulated from it. The two circuits are not physically connected in any way. In the usual hook-up for the trap, the outside coil is connected between the antenna lead-in and the receiving set, as in Fig. 1.

With the specifications given, no difficulty should be found in constructing this wave-trap after reference is made to the diagrams. Fig. 2 shows the wave-trap completely assembled before it is mounted in a cabinet, while Fig. 4 is a diagrammatic drawing of the wiring plan and Fig. 3 shows the front panel arrangement.

It will be noted that the wave-trap is designed with four binding posts which allow it to be used in many different ways in various circuits and combinations. The most common and useful hook-up makes use of only binding posts Nos. 1 and 2, either one of these being connected to the antenna lead-in while the other connects to the aerial binding post on the receiving set.

OPERATION

AFTER the wave-trap has been constructed, its operation is comparatively simple.

The receiving set should first be tuned approximately to the interfering station which it is desired to eliminate. Then the wave-trap dial should be varied slowly until the signal from the interfering station disappears or is reduced to minimum strength. The dial is then left in this position and the receiving set is returned to

whatever station it is desired to receive. Unless interfering stations are very close or other unusual conditions obtain, it will generally be found that an interfering station cannot again be found on the tuning dials of the receiving set until the trap has again been adjusted to receive it.

A unit of this kind will usually eliminate but one interfering station at a time. If there is more than one station creating interference, two or more traps may be used in series. By eliminating all local stations successively in this

manner, it becomes possible to work through to long distance without local interference of any kind.

AN EMERGENCY AERIAL OR GROUND

ANOTHER interesting and often very useful hook-up is as follows:

Connect binding post No. 1 on the trap to aerial binding post on receiving set. Binding post No. 2 is left open or unconnected, binding post No. 3 should be connected to the ground binding post on the receiving set, and the ground wire should be connected to binding post No. 4.

Tuning operations are then done with both the trap and the receiving set. The signal strength when using this hook-up is not as great as is obtained with an ordinary aerial, but in many cases fairly long distance reception can be accomplished. Moreover, static interference is considerably less than when a large aerial is used.

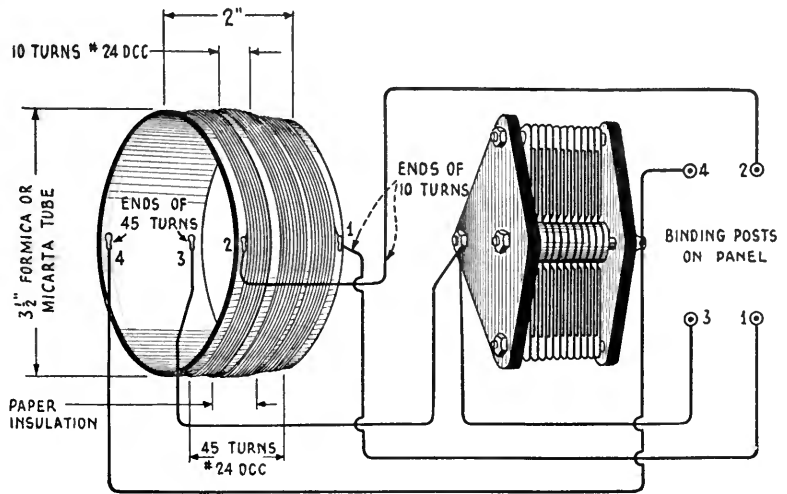

FIG. 4

Wiring plan of the wave-trap

If there is an aerial but no ground available, this same hook-up may be utilized in place of a ground connection by merely connecting the aerial lead-in instead of the ground connection to post No. 4.

HINTS TO THE EXPERIMENTER

I WOULD suggest that the coils be wound on a thin bakelite or impregnated cardboard tube. The two windings may be separated by a thin piece of writing paper or empire cloth and a thin coat of shellac may be applied to each winding as it is finished, to hold it in place and to exclude moisture. After each coil is shellacked, it is a good plan to touch a match to

it and let the alcohol burn out. This bakes the shellac into the winding, driving out all of the moisture, and does not burn the insulation. If it is desired, either the finished coil or condenser may be purchased ready to use.

After the condenser and filter coil have been mounted on the panel and the unit completely assembled, it can be fastened in a cabinet by means of small wood screws.

In congested localities, where interference prevails, the wave-trap is certainly an indispensable accessory for perfect reception. It is not only the solution of the interference between local stations, but adds immeasurably to the opportunity for long distance reception.



AN EYEFUL GETTING AN EARFUL

When Johnny Hines, having "slipped the cans on," listens enraptured through a phone-cord made of clothes-line, nothing short of Hope Hampton, co-star in "Classics of the Screen," can wrench the observer's fascinated eye away from him



What Our Readers Write Us



Wanted: "A Small and Pretty Works"

SEVERAL months before the earthquake took place in Japan, an incipient radio fan in Tokio sent the following letter to the Atlantic-Pacific Sales Company. Mr. Raymond Travers of that company wrote us: "Not only because he mentions RADIO BROADCAST, but believing this will perhaps give you a smile in a busy day, I am sending it on to you."

SIR:

According to RADIO BROADCAST magazine I have known that wireless telephony have been sold by your store, because I have written to ask about wireless telephony at once. Send radio catalogue and wireless telephony to me as soon as possible if you please. It is usefull works, is it not? I want about \$8 to 20\$, & I should like to know next,

"How miles can we hear, speech with it,

Is there a small & pretty works.

How \$ will it use to send it from your place to here.

Does it sensitive by every a little waves."

Send catalogue to as soon as possible if you please. Then good-bye.

So Say We All of Us

PROBABLY most of the broadcast fans who read the following letter will agree with Mr. Barteau's colorful protest against the spark interference that makes many a listener-in sit back from his receiver and think ungentle thoughts. We have long felt the injustice done by the operation of commercial stations on wavelengths near those used for broadcasting, and have published our own protests from time to time, in the hope that the commercial companies would see the advisability of changing the particular length (and breadth) of the waves used by their stations.

MR. ARTHUR H. LYNCH
Editor, RADIO BROADCAST,
Garden City, L. I.

MY DEAR MR. LYNCH:

Can you tell me if there is likely to be any relief from this code, now or ever? I can't understand

why such a hullabaloo was made about broadcasting interference when it was of the utmost insignificance compared to the inferno and pandemonium that is caused by the wireless telegraph! There are dozens of 'em hammering away every evening all the time—anything you don't want, from the peep of a sick chicken to the wind whistling through a handful of seaweed; screeching, rasping, gurgling and roaring all combined. Oh, it's wonderful!

Then the fellow that holds the key down indefinitely—he should be murdered in cold blood. A lad did this the other day for 32 minutes. How much longer I don't know, for I gave up to him then. About 90 per cent. of this ship-shore stuff is nothing but "gush"—"Wish you was here, lovely" and such stuff—that could just as well be held up till the morning.

It seems a shame that radio reception must be almost utterly spoiled in this manner, when there is really no need of it. The Army and Navy could move up and make room for these fellows above the broadcasting wavelengths, or the ship-shore stations could keep off for an hour or two in the evening.

I am an old commercial tel. opr., but I didn't make a noise like sandpapering a brick, causing good church-going Christians to spend hours cussing me.

Yours very sincerely,

E. M. BARTEAU

Brookhaven, N. Y.

An Appreciation of Mr. Seager's Article

MR. SEAGER, mentioned in the following letter from a Cuban enthusiast who built a set according to his description in the March, 1923, issue, won second place in our "How Far Have You Heard on One Tube?" contest. When you think of it, it is not easy to tell a non-technical reader all that is necessary to enable him to build a comparatively complicated and delicate piece of apparatus, and we are glad to receive letters like this one—as we have on many occasions—indicating plainly the practical benefit of the articles that appear between these covers.

(And let us add here, while on the subject, that we wish everyone who has had either success or failure with apparatus made according to instructions published in RADIO BROADCAST,

would drop us a line and tell us the what, the why, and the how of it.)

MR. ARTHUR H. LYNCH, *Editor*,
RADIO BROADCAST,
Doubleday, Page & Co.,
Garden City, N. Y., U.S.A.

DEAR SIR:

I want to congratulate Mr. E. V. Seager on the explanation he gives, in the March issue, of his inimitable set; and I also want to thank RADIO BROADCAST for its splendid diagrams and circuits upon which anybody can depend entirely.

I have been reading RADIO BROADCAST for the past three months and enjoy its explanations on constructing sets made with the least effort and most efficiency, but Mr. Seager's explanation of how to make and operate a Practical Long-Range, Single-Tube Receiver is wonderfully complete and clear and easy, because after one reads it, one can have no doubt whatever; there is no question to be asked; there is no detail omitted.

I have made a receiver exactly as he described and last Sunday night at about ten o'clock, Havana time, we heard Memphis Electric Company, Memphis, Tenn., but it soon died out and I could never locate it again. Friday night, we heard WGY, Schenectady, N. Y. very clearly; we got in on the end of the program, heard three or four numbers, and heard them signing off at 11:55 Schenectady time, as the announcer said (10:25 Havana Time.)

Assuring you that I think RADIO BROADCAST is filling a splendid mission, I remain,

Very truly yours,

JOSE MANUEL PONCE DE LEON.
Calle Concordia 30, altos
Havana, Cuba.

We Have the Most—Let's Have the Best

Editor, RADIO BROADCAST,
Doubleday, Page & Co.,
Garden City, Long Island.

DEAR SIR:

No one who listens-in consistently can fail to realize the enormous force that broadcasting will one day become. I can see in it the vision of the greatest institution of learning that can be conceived, the eventual broadcasting of definite courses of education that must inevitably supersede the hodge-podge of lectures and talks now being given. Even to-day the air carries knowledge and information—which is education—that is being injected into countless minds in the guise of entertainment, as for instance the description of musical works given by the announcer during the more important concerts. It is probable that at the beginning of broadcasting the majority of listeners did not know the difference between a sonata and a fugue; but by now they cannot

help but have acquired some appreciation of music and understanding of many musical terms.

The possibilities are vast, and it is to be hoped that there will be little delay in their realization. One of the advantages of seeing the climax of a movement while it is yet young is that stumbling blocks can be recognized and cleared away; it seems to me, therefore, that any one who has a vision of the possibilities of broadcasting, and an idea for its improvement and development, should come out with it, that it may be estimated and discussed. May I suggest that you create such a symposium?

I should like to call attention to a detail; a minor one, it is true, but one with a psychological bearing that gives it importance. This is the need for selecting educated minds for the announcers, who are listened to with close attention. If broadcasting is to be educational, an announcer should use cultivated language; his pronunciation and grammar should be correct, the tones of his voice those of education and culture. At the present, this is far from being the case, and in consequence, untold numbers of listeners are being led astray in matters of pronunciation, grammar, and the correct use of our language. No one, I think, questions the impression that is made by a cultured voice; its very tones are an indication of a background of education and refinement. Such is the voice that should be most frequently heard by the radio audiences, for it would be a continual example of an ideal toward which the average man and woman might well strive. Do not let them hear a slip in grammar, a fault in diction, or a mispronunciation, be it of an English word or the name of a foreign composer. Unquestionably, the announcer is a teacher. Let him teach correctly.

For understandable broadcasting, the timbre and quality of the voice is of an importance that we all appreciate. Clarity is in part distinct enunciation, of course, but the voice quality is an element that seems to me to merit particular attention. Some voices carry, and are easily understandable, while others are just the reverse. It would be interesting to have one of the broadcasting stations make a test of a number of speaking voices of various qualities to determine by the reports of the listeners which had the best reception. This would lead to a recognition of the desirable qualities, and to their cultivation.

For another point, I think that there should be no interval in a program, even that of the customary "One minute, please," when the station is silent. I recommend that each station adopt a distinctive low-toned sound maker, be it a series of bells, plucked harp strings, or any pleasing sound, that would be switched on to bridge an interval, as an indication to the listener that he "had" the station. This would assure a continuity that at present is lacking, and that is likely to be disconcerting.

All of which is submitted for your consideration.

JAMES OLIVER.

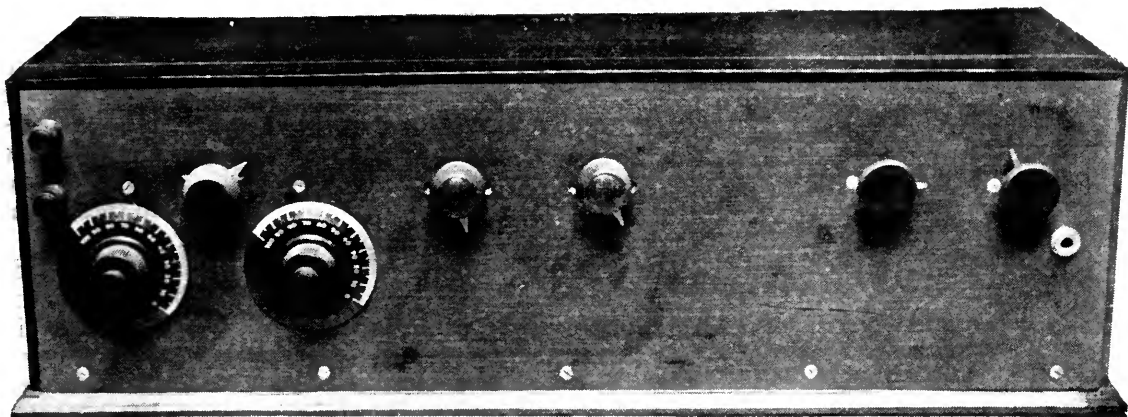

MR. ELTZ'S SEVEN-TUBE SUPER-HETERODYNE

It has but two tuning controls. The simplicity of operation of a set of this type is sure to make it increasingly popular

How to Build a Super-Heterodyne Receiver*



By GEORGE J. ELTZ, Jr.



The value of the super-heterodyne receiver has been better appreciated by the Radio Club of America than in most other circles. One reason for this may be that Edwin H. Armstrong, inventor of the super-heterodyne, is a member of the Club. Mr. Eltz has been an enthusiastic supporter of this wonder circuit since Armstrong introduced it, and in this paper he describes a receiver incorporating several recent improvements.—THE EDITOR.

THE super-heterodyne, or double-detector receiver, is now a practical piece of apparatus for use by the radio amateur and broadcast listener. To date there has been developed no other circuit which is either as selective or as sensitive. The chief drawback in the operation of this circuit has been that vacuum tubes as manufactured in the past required filament currents of about one ampere each. This high filament current necessitated the use of large batteries, making the operation of the super-heterodyne too expensive a luxury for many fans. But the new vacuum tubes, with low filament consumption, bring this type of receiver within the reach of many more of us.

A super-heterodyne may be constructed with practically any type of vacuum tube on

the market to-day. Best results can probably be obtained by using the UV-201-A (C-301-A). Good results, however, can be had with the UV-199, WD-11 and WD-12 tubes.

Before going into the actual construction of the super-heterodyne, it will, perhaps, be well to consider just what happens in the circuit. It was developed by Major E. H. Armstrong, at a time when high-frequency, radio-frequency transformers were unknown. Practically the only method of radio-frequency amplification in successful use at that time was amplification by means of resistance coupling between the stages. The amplification obtained per tube by this method at high frequencies was extremely low, a voltage amplification of three or four per tube being exceptionally good. At low frequencies, however, that is, in the order of 50,000 cycles or a wavelength of 6,000 meters, amplification of a considerably higher value, perhaps as high as 6 or 7, could be obtained.

In brief, its action is as follows: the fre-

* For other articles dealing with the super-heterodyne, see "A Super-Sensitive Long-Range Receiver," by Paul F. Godley in RADIO BROADCAST for February, 1923, and "A Practical Super-Heterodyne with 199's," by Walter Van B. Roberts in RADIO BROADCAST for August, 1923.

quency which enters the loop or antenna as the case may be, is, we will say, of the order of 1,000,000 cycles, equivalent to 300 meters. This frequency is modulated by the radio transmitting station, whether telephone or telegraph, and is detected at the receiving station by the tube called the first detector tube. As part of the receiving set, a vacuum-tube oscillator is set up capable of producing frequencies of the same order as those which are to be received. The loop or antenna circuit is tuned to the incoming frequency. The oscillator in the receiving set is adjusted to a point 50,000 cycles above or below the incoming frequency. The result is a beat-note, between the incoming frequency and the frequency in the set, of 50,000 cycles. This beat-note is modulated in exact accordance with the incoming frequencies. All this action occurs in the first detector tube.

The output of the plate circuit of the first detector tube is then fed into the primary of a radio-frequency transformer designed for best operation at frequencies of about 50,000 cycles or 6,000 meters. The voltage amplification obtained at this frequency by means of transformers is high, perhaps as high as 12 or 14. After running through a number of radio-frequency transformers of this character, and their vacuum tubes, the frequency is then impressed on a circuit tuned sharply for 50,000 cycles. In this circuit, the higher frequencies which may have passed the amplifying trans-

formers are eliminated and a coil connected with the tuned circuit impresses on the grid of the second detector tube, nothing but the 50,000-cycle modulated beat-note. This beat-note is detected by a second detector tube, the plate circuit of which supplies the power for operating a telephone headset, loud speaker, or audio-frequency amplifier.

In Fig. 1 is shown a circuit which corresponds in action to the one described above. Here the super-heterodyne is shown in operation in connection with a loop. The loop is tuned by a small variable condenser and the output impressed on the grid of the first detector tube. The transformers used for the amplification of 50,000 cycles, or as it is commonly called the intermediate-frequency amplifier, are the familiar Radio Corporation UV-1716 transformers. They are extremely efficient at a frequency of 47,500 cycles, which is the frequency used in the circuit shown in Fig. 1. Three of these transformers are used before the second detector. The "special transformer" consists of an air-core transformer, having a primary consisting of 200 turns of No. 29 double silk-covered wire, wound on a 1" wood or bakelite core and a secondary wound immediately on top of the primary of 1500 turns of No. 36 double silk-covered wire. The length of the core is $\frac{1}{4}$ ", the outside diameter of the combination being approximately 3". No particular care need be taken in winding this transformer. It is important, however, that approximately

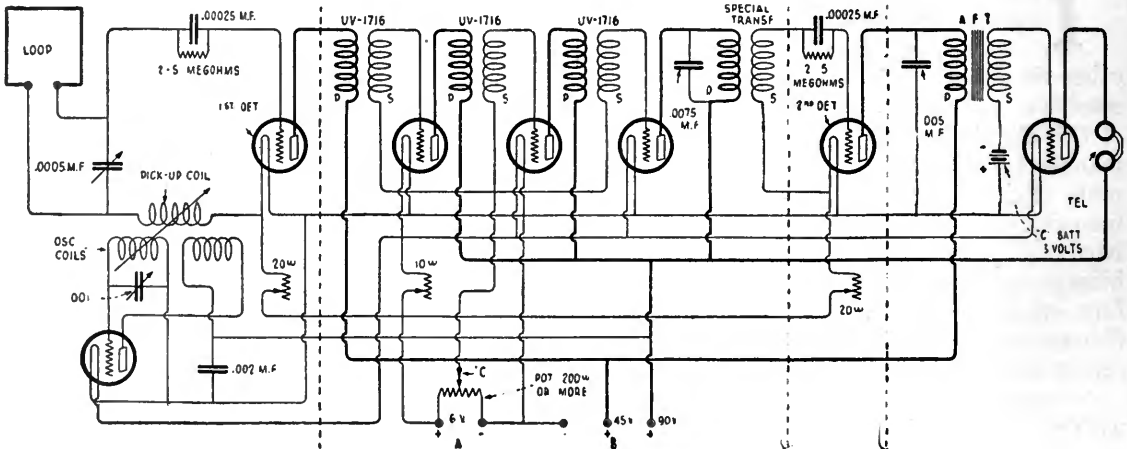

FIG. 1

The dotted lines indicate the four sections into which we may divide this super-heterodyne circuit to make it more easily understandable. In the first section (from the left) we have the wave-changing unit, then the intermediate-frequency amplifier, then the detector and finally the A. F. amplifier. For experimental purposes, it may be found advisable to arrange the super-heterodyne in separate cabinets provided with binding posts for connecting them together. By this arrangement, various combinations may be tried with very little difficulty.

the correct number of turns be used. Across the primary of this transformer is placed a fixed mica condenser of .0075 mfd. capacity. This condenser, in combination with the primary and secondary, fixes the frequency at 47,000 cycles, which is a particularly efficient point for amplification with the UV-1716 transformers. Between the plate of the second detector tube and the negative side of the filament, is connected a small condenser of .005 mfd. capacity, which acts as a by-pass condenser, preventing the leakage of any of the 50,000-cycle current into the audio-frequency amplifier.

BUILDING THE OSCILLATOR

THE oscillator shown at the lower left-hand corner of the diagram may be constructed of two honeycomb coils, a 35-turn coil being used in the grid circuit and a 25-turn coil in the plate circuit, or it may consist of the same number of turns wound on a Bakelite tube 3" in outside diameter. The small coil shown coupled to the grid coil of the oscillator marked "pick-up coil" should consist of 30 turns of No. 36 double silk-covered wire wound on a form 1" in diameter, $1\frac{1}{4}$ " long. This coil should be capable of rotation to vary the coupling with the grid coil. Once set, this adjustment need not be changed except when vacuum tubes are changed. Only three rheostats are necessary, and if desired the number may be reduced to one, although when this is done the detector tubes cannot be operated quite as effectively. In the set shown in the photographs, four rheostats are used, one of which controls the filament current of the oscillator. This is not absolutely necessary since the amount of pick-up voltage can be readily controlled by means of the pick-up coil.

THE COMPLETED CIRCUIT

THE circuit given in Fig. 1 is one which has proved to be simple to operate, extremely selective, and very sensitive. The sensitivity of a super-heterodyne circuit of this type is far ahead of any other receiver even though the same number of tubes are used. The selectivity is not approached by any other receiver. With a receiver of this type it is possible to receive distant stations while local stations no matter of what power are operating. This high degree of selectivity is obtained due to the fact that not only is the inherent selectivity of the loop part of the super-heterodyne,

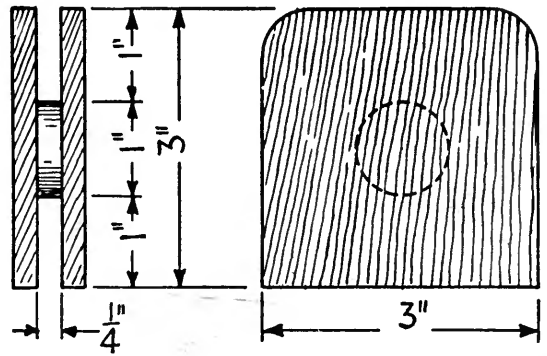

FIG. 2

This special transformer is used to couple the last R. F. tube to Detector Tube No. 2 in Fig. 1, and provides a sharp resonant point for the radio-frequency circuit. The walls of this transformer may be made of bakelite or hard rubber. The primary is wound with 200 turns of No. 29 D. S. C. and is separated from the secondary, which has 1500 turns of No. 36 D. S. C., by several layers of empire cloth

but also because the beat-note between the incoming frequency and the local oscillator must be exactly obtained or it will not pass the transformers and the tuned circuit before the second detector. In order to insure high selectivity, one precaution must be taken. Unlike other radio amplifier circuits no regeneration is obtained in the loop circuit. This being the case, the resistance of the loop circuit must be made as low as possible. Loops wound with Litzendraht wire, and condensers of very low resistance, must be used. Regeneration to a certain extent will be obtained in the intermediate circuit amplifier, although if much regeneration is present some distortion is apt to occur.

SHIELDING

FOR a set of this character to operate properly it must be carefully shielded. This precaution must particularly be taken with the intermediate-frequency amplifier, because the amplification obtained per stage is extremely high, and the intermediate-frequency amplifier is apt to oscillate unless properly shielded. If oscillation occurs, of course, no amplification is possible. If the receiver is built with the circuit of Fig. 1, it should be possible to make the grid of the intermediate-frequency amplifier tubes at least $4\frac{1}{2}$ volts negative without oscillation occurring. If this condition can be obtained, the amplifier is working properly. A small C battery should be inserted at the point marked "C", if the potentiometer does not supply sufficient negative C voltage to

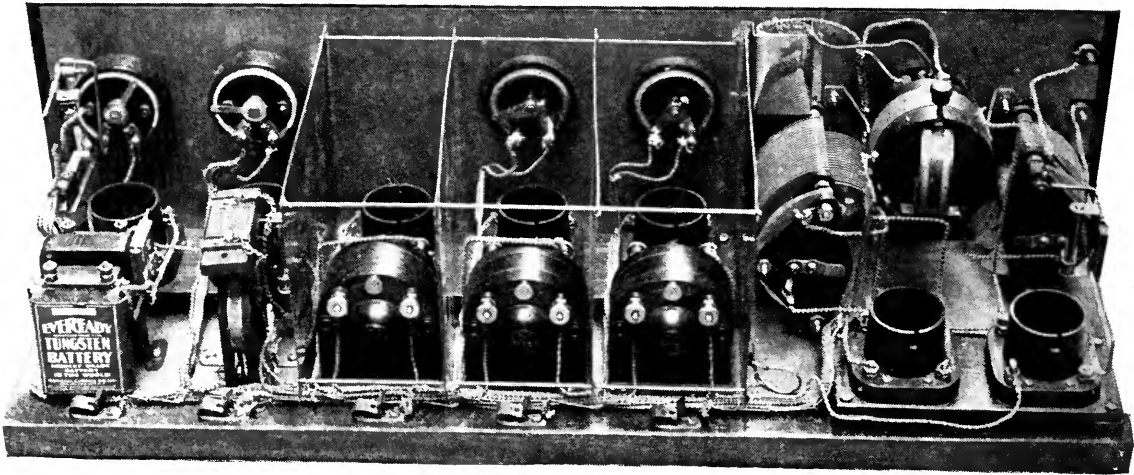

REAR VIEW, SHOWING METAL SHIELDING ENCLOSING THE INTERMEDIATE-FREQUENCY STAGES
The layout may seem a bit complex, but none of the four parts which it comprises—wave-changer, I. F. amplifier, detector, A. F. amplifier—is particularly difficult to build. The circuit diagram, Fig. 1, shows clearly this division into parts

approach a point of oscillation. The values of A and B battery will, of course, depend on the vacuum tubes used. Fig. 1 gives the value for UV-201-A tubes.

WHAT THE RECEIVER WILL DO

WITH a super-heterodyne of this character it should be possible to obtain loud speaker operation on any good broadcasting station over a distance of at least 1500 miles under any condition. Under good conditions the Pacific Coast stations have been heard in New York City on a loop 21 inches square. Signals were of sufficient intensity to operate a loud speaker with enough volume to be heard over a room of moderate size. If desired, another UV-1716 transformer may be added to the intermediate-frequency amplifier. If this is done, additional care should be taken to see that the intermediate-frequency amplifier is most carefully shielded, otherwise the added amplification will be lost due to the feed-back through the wires of the set.

METHOD OF WIRING

IN THE photograph above, the wires used for connecting the filaments and the wires bringing the B battery voltage to the transformers, detectors, oscillator, etc., are shown combined in a single cable laced together and shellacked. This method of wiring is simple, neat, and introduces no losses into the circuit.

It is particularly convenient when shielding is used as it eliminates a great deal of the cutting and drilling of the shields which would be necessary if bus-bar wiring were used. The wires leading from the grid and plate of the vacuum tubes to the transformers should not be placed in the cable. These wires must be run separately, or a considerable loss will result. The UV-1716 transformers should be connected with the terminals marked 3 on both the primary and secondary to the plate and grid circuits of the tubes in question. The terminal marked 1 is nearest the core. The terminal marked 3 is the outside terminal of both the primary and secondary winding and has the highest induced voltage. The wires leading to and from the grid and plate of the oscillator and oscillating coils should not be cabled. The small .002 mfd. condenser used in connection with the oscillator is for the purpose of grounding any oscillator frequency which may tend to go back through the cabled wires.

The tuning of the super-heterodyne is at first more or less difficult, particularly when it is desired to pick up stations whose wavelengths are not exactly known. Both condensers should be operated at the same time, with the dial readings approximately the same, the object being to keep a uniform space of 50,000 cycles between the two condensers. With a little care and experience this can be readily learned and the great advantage of selectivity obtained.

In the R-B-lab

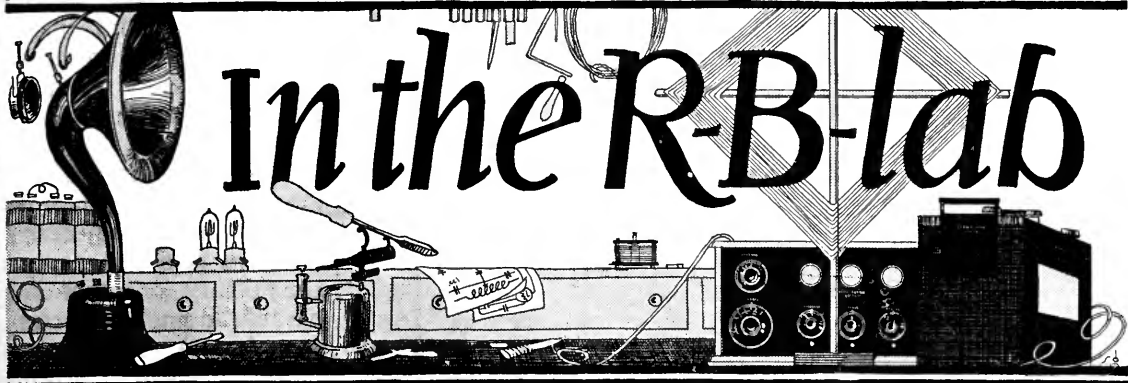

The "Lab" department has been inaugurated by RADIO BROADCAST in order that its readers may benefit from the many experiments which are necessarily carried on by the makers of this magazine in their endeavors to publish only "fact articles" backed by their personal observations.

Under this heading will be published practical pointers, brief write-ups of interesting experiments, additions to and improvements on previously published circuits—in short, anything of genuine value and interest to the reader, which, due to the brevity with which it can be covered, does not justify a special article.

RADIO BROADCAST will be pleased to buy from its readers, at prices from three to five dollars, commensurate with the value of the data, kinks, devices, original ideas, etc., with photographs if possible, which the Editor may consider eligible for this department.

Address all communications to the R. B. Lab Editor.

REBUILDING YOUR CHARGER

(Suggested by HENRY G. MULLER, Radio 2BH)

INEFFICIENCY, noise, and a low charging rate are among the defects inseparable from some of the commercial bulb rectifiers used for the home charging of batteries. A satisfactory rectifier should eliminate all avoidable losses, be silent, and deliver a current in the neighborhood of nine amperes. Practice indicates that the average tube and battery are not injured by so high a charge, and as this secondary current can be secured from the conventional charger without increasing the input (by increasing efficiency, i. e., eliminating losses) the result is a quicker, more satisfactory charge at less cost.

The principal object in re-mounting is to eliminate the iron box and frame in which

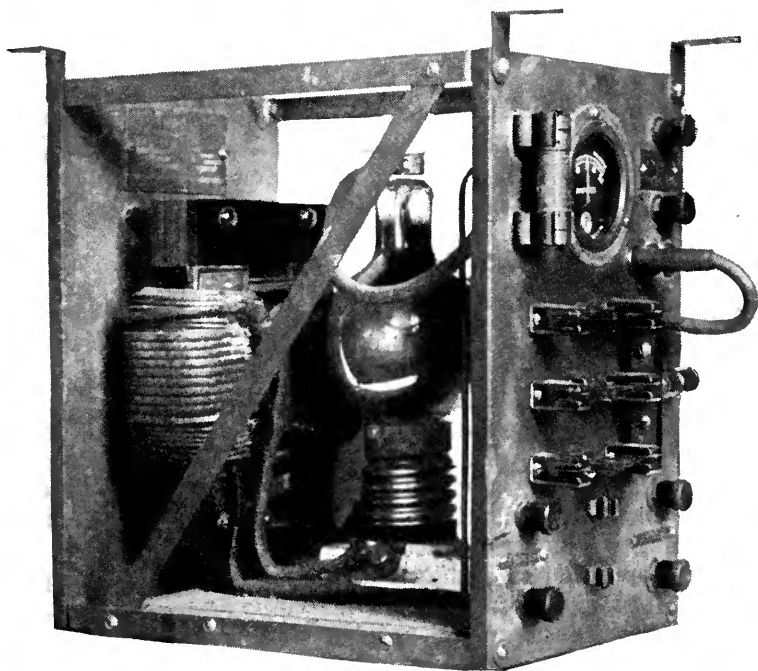

FIG. 1

The rebuilt charger, furnished with brackets for mounting it out of the way beneath the operating table

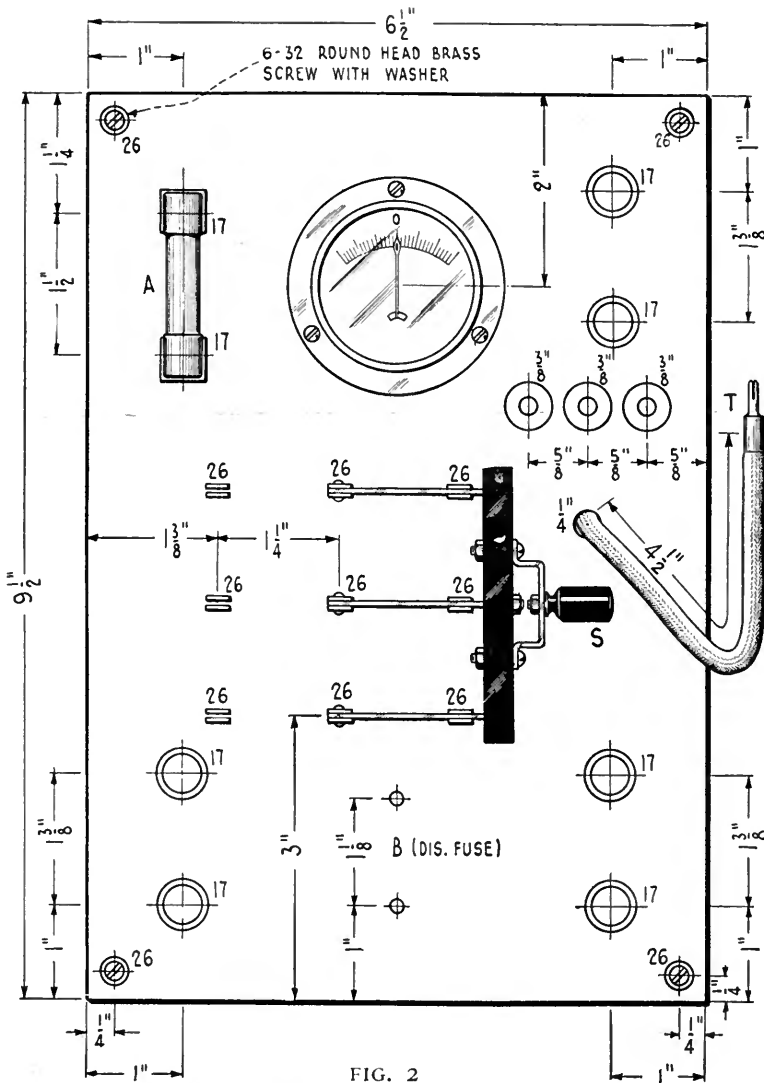

FIG. 2
A working drawing for the charger panel

in the rectifier circuit. The meter reads both charge and discharge up to fifteen amperes, and is the type mounted on automobile instrument boards.

Mr. Muller, owner of amateur station 2BH, in order to obtain an adjustable charging rate has tapped the primary (or rather that part of the single coil acting as primary) of the auto-transformer with which his rectifier was equipped, at thirty and sixty turns on the thin wire side, bringing leads from these taps and from the upper end of the winding to the home-made jacks on the right of the panel. The jacks were made from $\frac{3}{8}$ " round-head machine screws about $1\frac{1}{2}$ " long. The heads were turned straight, leaving a flange, and drilled with a number eleven drill. These jacks take the plug T (Fig. 2) which was made from a De Forest honeycomb plug. An ordinary switch lever with conventional contact points may be substituted for the plug and jack arrangement; however, as the adjustable winding is not necessary (in some cases it is even undesirable), the switch or plug

may be dispensed with, and the transformer winding connected directly across the 110-volt line.

the commercial rectifier is cased, and which absorbs a considerable amount of energy which would otherwise be spent as useful charging current. If the parts are removed from the metal box, and simply connected together on a base-board, the charging rate will sometimes be found to have jumped two to four amperes.

Fig. 1 shows a rebuilt charger with brackets for mounting it beneath the operating table. Separate fuses are provided for charge and discharge. The plug permits different charging rates, and the functioning of the apparatus is controlled by the triple-pole-double-throw switch, one side connecting the battery for charge and discharge through the tubes, and the other starting the charger and throwing the battery

Fig. 3 shows the rear of panel connections for a rectifier of the Tungar type. X leads to the large wire end of the winding, and jacks 1, 2, and 3 to the taps. Throwing the switch to the left places the battery on charge, and to the right, on discharge. Fuse A (charge) should blow at ten amperes, and B (discharge) at five amperes.

The rear connections for all types of transformers will not be the same, and the circuit should be carefully traced, and the panel diagram (Fig. 3) altered if necessary, before the set is demounted from its original container and base.

The transformer is mounted on the rear panel, which is the same size as the switchboard, by bolts passing through the core and the panel. The bolts should be about four inches long so that by means of three nuts the transformer may be held away from the panel. The front and rear panels are separated by eight inches of angle brass (eliminate iron as far as possible from the

construction) with one diagonal brace on each side. The constructional details are suggested in Fig. 1, which also shows the socket with bulb mounted on a wooden base. Nothing smaller than No. 10 wire should be used in making the secondary connections of the charger, and No. 8 is advisable in wiring the socket.

The R. B. LAB will be pleased to adapt any circuit, which may puzzle our readers, to the panel in Fig. 2, and this department plans, for next month, an easily wound transformer, and hook-up designed especially for this panel, enabling the experimenter to build a complete and superior charging unit for much less than the cost of the standard instrument.

A CONDENSER SWEEPER

(Suggested by KARL R. LESH)

DUST (as well as pieces of solder and stray bits of insulation, etc.) accumulates very quickly between the plates of variable condensers, and aside from the annoyance which the knowledge of its existence gives, it has several undesirable electrical effects. It increases the dielectric loss, reducing the efficiency of the apparatus, and under certain meteorological conditions the tiny particles accumulate static charges, which, in discharging, add to the sounds caused by the prevailing atmospheric disturbances. In low-power bulb transmitters, where receiving variable condensers are often shunted across high potentials, an accumulation of dust often leads to the breakdown of the condenser.

But enough! The dust is there; it and other accumulations can be swept away by a pipe cleaner (the kind sold in cigar stores at five cents a package) inserted between the plates.

A CONVENIENT HEAD-PHONE HOLDER

By EDWARD T. JONES

WHENEVER there are more persons present than head-sets, making it necessary for someone in the crowd to wait his turn to listen-in to the concerts, someone

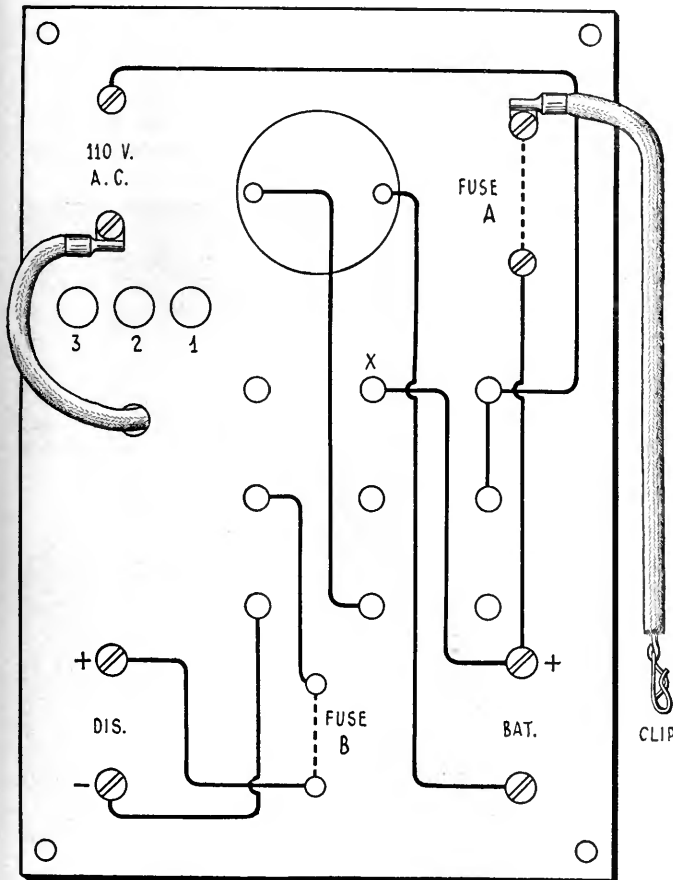

FIG. 3
Rear view of the panel

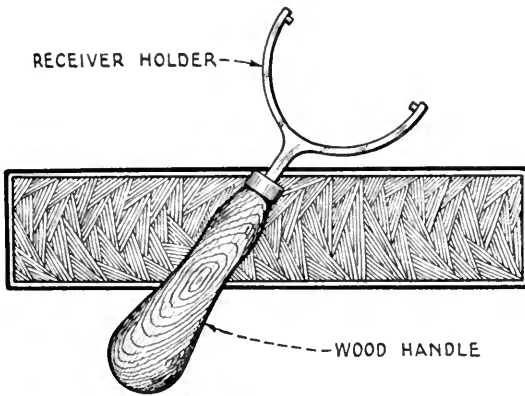

FIG. 4

will remove a receiver from his head-band and lend it to his neighbor.

This arrangement is satisfactory as far as it goes. However, if the set is of the regenerative type, and no amplifier is being employed, the set will be put out of operation by detuning as soon as the listener touches the metal backs or tips of the receivers.

It is also very tedious to hold the single receiver to the ear, grasping it in the awkward hold which its shape imposes.

Taking the above into consideration, I was prompted to devise a holder for the receiver, and evolved the device shown in Fig. 4. The wooden handle was purchased at a five and ten cent store, and the piece which clamps the receiver was taken from an old Baldwin head-band.

It is easily constructed, and costs but a few cents.

BUILDING THE LABORATORY

THE LAB'S suggestion for this month's acquisition to the budding laboratory is a hydrometer and a crystal detector. The former will cost from seventy-five cents to a dollar, and its most convenient form is that shown in Fig. 5. This consists of a large, syringe-like glass tube and bulb, with a few inches of rubber pipe for drawing up a quantity of the electrolyte from the storage battery. Within the large tube is a small graduated glass float.

A hydrometer is used for determining the state of charge and discharge of a lead-plate-and-acid storage battery from the specific gravity of the electrolyte or fluid within the cells.*

*See "The Storage Battery in Radio Service," in RADIO BROADCAST for August, 1922.

The specific gravity of any liquid is a comparison of its weight to the weight of the same quantity of water. Sulphuric acid is heavier than water. A tube, such as the hydrometer float, weighted so as just to float in sulphuric acid will sink in a glass of water. Thus the battery's electrolyte, which is a mixture of sulphuric acid and water, is heavier than water. But in the process of discharge, sulphuric acid is absorbed into the plates of the battery, leaving the remaining solution much weaker, or lighter in weight. As the battery is recharged, the acid is forced from the plates back into the solution, which, on full charge, regains its original acidity. Thus the measuring of an electrolyte's specific gravity will indicate the amount of acid absorbed by the plates, i. e., the state of charge!

In testing the battery with the hydrometer, the vent caps are removed (and left off during charge) and enough electrolyte withdrawn from the cell being tested to float the graduated scale (Fig. 5), each cell being tested separately. A fully charged battery should read 1280, half charge about 1215, and it should be placed on charge at 1150 or sooner. The battery should never be left for any time at this lower reading.

If the battery refuses, on a continued charge,

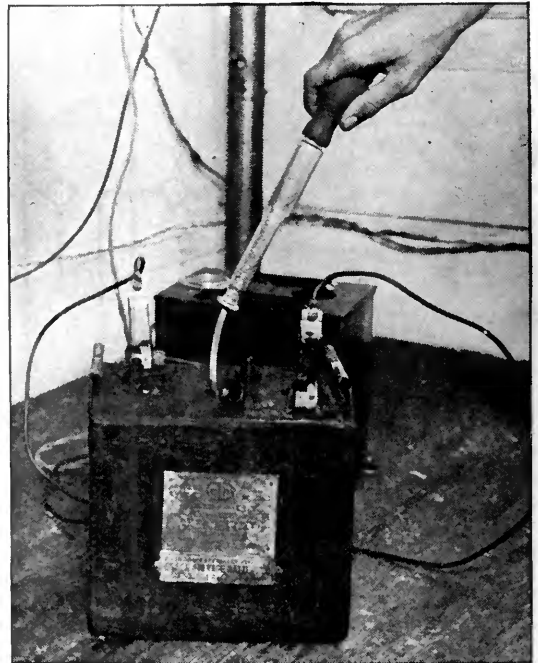

FIG. 5
Determining the state of charge
of a battery with a hydrometer

to come up to the required specific gravity, but gases freely, and otherwise exhibits indications of a full charge, there is probably insufficient acid in the electrolyte. A *small* quantity should be added to the deficient cells until the desired reading is obtained. Add acid only to fully charged batteries. This job, however, is best done by an expert.

The intelligent use of a hydrometer in the care of a storage battery will add years to its life.

THE CRYSTAL DETECTOR

A *good* crystal detector is an important addition to a radio laboratory (In many cases, it is the beginning of one.) It is most useful as a stand-by for the throwing together of an auxiliary set*; it is almost indispensable for certain wavemeter experiments, and the advent of reflex possibilities (many such circuits recognizing the crystal as the best available detector) has given to this ancient form of detection a new importance.

The crystal detector rectifies the alternating currents induced in the antenna system by the passing radio waves, through its inherent property of unilateral conductivity, viz., passing a current in only one direction. One half of

*See "Crystal Receivers are Well Worth While," in the August, 1923, number.

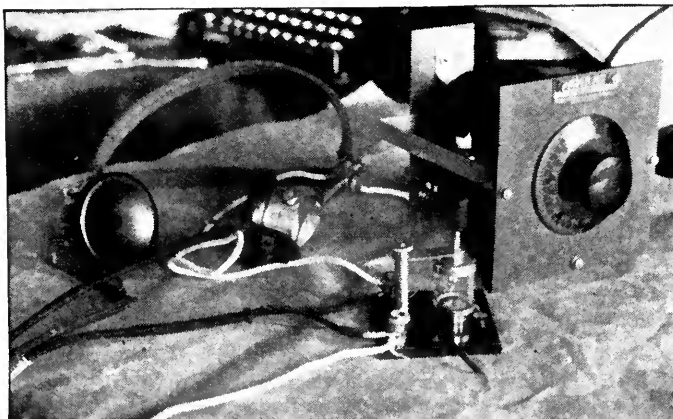

FIG. 6

Phones, crystal, and variometer—a complete receiving set

the alternations are discarded and the other half passed on as rapidly pulsating D. C. (direct current).

Galena is deservedly the most popular crystal, and Fig. 6 shows such a crystal in a well designed mounting (cost \$2.00), hooked to a rapidly thrown together auxiliary set. The "set" consists merely of antenna, variometer, detector and ground in series, with the phones connected across the detector.

This type of detector is very easily adjusted, but with a particularly obdurate crystal, the buzzer test described on page 321 of the August, 1923, issue may be used.



Supplemental List of Broadcasting Stations in the United States

LICENSED FROM AUGUST 8 TO AUGUST 24 INCLUSIVE

(Next month—revised list of all U. S. and Canadian broadcasting stations)

CALL SIGNAL	STATION	FREQUENCY (Kilocycles)	WAVE-LENGTH	POWER WATTS
KFJM	University of North Dakota, Grand Forks, N. D.	1310	229	100
KFJQ	Electric Construction Co., Grand Forks, N. D.	1190	252	5
KFJR	Dixon, Ashley C., & Son, Stevensville, Mont.	1160	258	50
KGB	Tacoma <i>Daily Ledger</i> , Tacoma, Wash.	1190	252	50
WTAH	Ferro, Carmen, Belvidere, Ill.	1270	236	10
WTAJ	The Radio Shop, Portland, Maine	1270	236	50

DELETIONS FROM AUGUST 1 TO AUGUST 31

KFIJ	Platte, S. D.	WJAK	Stockdale, Ohio
KGB	Tacoma, Wash.	WJAP	Duluth, Minn.
KGO	Altadena, Calif.	WLAY	Fairbanks, Alaska
WEAD	Atwood, Kansas	WRP	Camden, N. J.
WGM	Atlanta, Ga.	WSAQ	Dartmouth, Mass.

The Grid

QUESTIONS AND ANSWERS

The Grid is a Question and Answer Department maintained especially for the radio amateurs. Full answers will be given wherever possible. In answering questions, those of a like nature will be grouped together and answered by one article. Every effort will be made to keep the answers simple and direct, yet fully self-explanatory. Questions should be addressed to Editor, "The Grid," RADIO BROADCAST, Garden City, N. Y.

WHAT THE GRID CAN AND CANNOT DO

WITH a view to making this department more efficient, and more valuable to our readers, we request that all those who write in to The GRID, consider their queries in the following light before submitting them to this department:

1. Is my question put clearly, concisely, and without ambiguity?

2. Have I stated every possible fact regarding my installation, or the set which I intend building, which may assist the editor in furnishing me with the information I desire?

3. Am I sure that the question which I am asking is not answered in the article to which it has reference? (Many questions are received which are covered fully somewhere in the articles that have prompted them.)

4. Has this question been answered in either The GRID or in a complete article in a recent issue of RADIO BROADCAST? (The majority of replies furnished by this department are references to late issues of this magazine in which the correspondent's question has been answered in every detail.)

RADIO BROADCAST cannot answer such questions as "What is the best set I can build?"; "What kind of an aerial shall I put up?"; "What is wrong with my receiver?"

The type of set you construct depends much more on your own ability and resources than upon the advice of any radio periodical. However, if you will state your mechanical facilities, the purpose for which you desire the set, DX, loop reception, etc., your radio experience, and the amount of money you care to invest, we can invariably give you helpful advice concerning the best set for you.

Likewise the antenna which you erect depends on many things. We may describe an ideal antenna which, due to geographical, financial, or other reasons would be impossible for the particular reader whom we were answering to construct. But if you will describe your present or contemplated antenna system, we shall be pleased to tell you if it is a good one, and suggest changes for bettering it if that is possible.

We have written to a great many readers that we cannot advise them what is wrong with their receiving sets. To diagnose radio difficulties, one must personally examine the faulty apparatus, put it through innumerable tests, and even then an expert is often balked for a time. To accomplish this by mail, on the scanty description of symptoms with which we are generally furnished, is, we regret, next to impossible. However, if the correspondent will describe to us in detail the manner in which the set acts or fails to act, i. e., the symptoms: the set itself (the parts, tubes, condensers, rheostats, jacks, transformers etc.); his past difficulties with it; the various attempts

which he has made to locate the trouble and the results of such tests, we shall be able to render him assistance in the majority of cases.

Questions dealing with little special points on construction peculiar to a set described in RADIO BROADCAST, but not covered in the article, should be addressed to the author of the story, care of this magazine. Any general questions will, of course, be answered through this department.

Your considerate attention to these details will expedite our handling of queries, and insure yourself against possible disappointment. There is an art in asking a question, and it is a genuine pleasure to answer one well put!

HOW TO BIAS A GRID

In reference to reflex sets and different amplifying apparatus, I have found mention of "biasing the grids" under certain conditions, without any further description of just what this "bias" means. I, and probably many other readers, are unfamiliar with this process, its cause and effect. I should appreciate any light you can throw on the subject.

A. A. M., Troy, N. Y.

BIASING the grid is the act of placing upon it a potential (voltage) other than that at which it would operate were it connected to the circuit through an uninterrupted, direct wire.

The functioning of the bias is more or less that of a brake; it stabilizes and limits (slows down) the action of the tube. The operation of a vacuum tube depends on and exists by the virtue of the electron stream passing

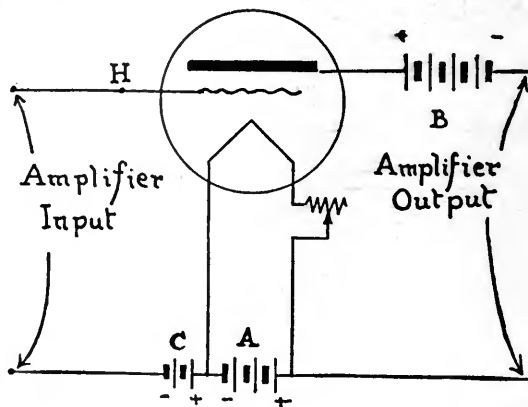

FIG. 1

Showing the position of the C biasing battery used to prevent distortion in the amplifying circuit



Ask any radio expert

THE first duty of a radio panel is to give satisfactory insulation, as any radio expert will tell you. The wise fan selects his panel with special care and insists on having one that supplies the proper insulation resistance.

Celoron Radio Panels provide satisfactory insulation under all conditions. They have high dielectric strength and great surface and volume resistivity, and do not warp or crack when exposed to moisture.

Cut in standard sizes

For your convenience, Celoron Radio Panels come ready cut in eight standard sizes. Your dealer will hand you the size you want, and you can begin to build your set at once.

Celoron panels are easy to saw, mill, and tap, and will engrave evenly without feathering. Each panel is

wrapped separately in glassine paper.

Select from the following standard sizes the panel that suits your needs:

- | | |
|---------------------------|----------------------------|
| 1—6 x 7 x $\frac{1}{8}$ | 5—7 x 18 x $\frac{3}{16}$ |
| 2—7 x 9 x $\frac{1}{8}$ | 6—7 x 21 x $\frac{3}{16}$ |
| 3—7 x 12 x $\frac{1}{8}$ | 7—7 x 24 x $\frac{3}{16}$ |
| 4—7 x 14 x $\frac{3}{16}$ | 8—12 x 18 x $\frac{3}{16}$ |

If your dealer cannot supply you, ask him to order, or write direct to us. Indicate by number the size you need. We also furnish Celoron in full-sized sheets and in tubes, and can cut panels in special sizes if desired.

This booklet free

Write for a copy of our booklet, "Tuning in on a New World," which contains a list of the leading broadcasting stations in the United States and Canada, an explanation of symbols used in radio diagrams, and several efficient radio hook-ups. It will be sent to you free on request.

To radio dealers: Send for special dealer price list showing standard assortments

Diamond State Fibre Company

BRIDGEPORT

(near Philadelphia)

PENNSYLVANIA

BRANCH FACTORIES AND WAREHOUSES

BOSTON

CHICAGO

SAN FRANCISCO

Offices in Principal Cities

In Canada: Diamond State Fibre Company of Canada, Limited, 245 Carlaw Ave., Toronto

CONDENSITE
CELORON ★
 STANDARD RADIO PANEL

from the heated filament, through the grid, to the plate. For the various operations, detecting, amplifying, and oscillating at greatest efficiency, the strength of this stream must be varied. In other words, for the most sensitive detection, the highest amplification, and the most powerful oscillations, the plate current must be regulated, and in such a manner as can only be accomplished by biasing the grid, i. e., placing an external charge upon it. A positive charge will increase the flow of negative electrons (unlike charges attract each other, while like charges repel) and a negative charge will lessen it. Where small plate currents are passed, this grid adjustment is easily secured by a condenser and grid leak. With higher currents more drastic means must be resorted to, and a battery is placed in series with the grid, imposing the charge which will regulate the current as is desired.

The abnormal condition which indicates the desirability or necessity of a bias, is evidenced by distorted amplification and howling. Fig. 1 shows how this may be overcome by biasing, "C" being the bias battery, which is referred to as the C battery. The bias should be adjusted, generally between $1\frac{1}{2}$ and $4\frac{1}{2}$ volts, until the most satisfactory point is secured.

A bias should never be necessary on a correctly designed two-stage audio amplifier if good tubes are used and the plate voltage (B battery) is not over sixty. If the set howls, the amplifying tubes should be reversed, the first step bulb being placed in the second stage, and vice versa. If this has no effect on the squeal, make sure that the connections have been made correctly, particularly in bringing down the grid through the transformer secondaries to the negative of the filaments. Also ascertain if you have conformed with the arbitrary rule of connecting the outside leads of the transformer windings to the grids and plates of their respective tubes. As a last resort, before biasing, look for an open (break) in the windings.

TUNED R. F. AMPLIFICATION

Please show a hook-up of one stage tuned plate radio frequency, detector, and two stages of audio, using UV-199's, honeycomb and a .0005 variable condenser for the radio frequency. Please tell me what ratio transformers to use in the audio amplifier.

S. M. La Salle, III.

In reply to our correspondent, we publish in Fig. 2 the circuit which he desires. However, operation is not confined to the UV-199, but will be quite satisfactory with any convenient combination of tubes, using detector and amplifiers, of course, in their respective circuits.

L₁ is a double slide or double tapped tuning coil (or it may be the secondary of a variocoupler, if the builder prefers) of one hundred turns of wire, tapped every ten turns, wound on a $3\frac{1}{2}$ -inch tube. C₁ is a 23- or 43-plate variable condenser. L₂ is the 40-turn honeycomb mentioned by our correspondent, but if desired, it may be wound with 50 turns of wire on a 3-inch tube. C₂ is the .0005 condenser.

R is a potentiometer approximating 400 ohms resistance. C₃ is the usual phone condenser of about .0015 mfd.

The four tubes, running from the antenna to the right, are the R. F. tube, the detector and two audio amplifiers. The transformers T and T are of standard design, and may be of the same ratio, that is, about four to one. On some occasions it is possible to obtain greater amplification by using a higher ratio on the first-step transformer, some engineers advising as high as twelve to one. This is immediately dropped, however, to four or three to one in the succeeding stages. The GRID has always obtained excellent amplification using transformers of the same comparatively low ratio throughout.

J₁ and J₂ are double-circuit jacks, while J₃ (which, if desired may be the same) has been indicated as a single-circuit jack.

If UV-199's are used, the B battery should not exceed 60 volts unless the tubes are biased.¹

The "A" battery sockets and rheostats will, of course, depend upon the tube used.²

The experimenter will probably find the radio frequency very difficult to tune, but the knack of it will soon be acquired with practice, and the results justify the trouble

¹See "the Best Battery Connection for the Tubes You Use," in RADIO BROADCAST for June, 1923.

²See "Rheostats for the Tubes You Use," in RADIO BROADCAST for October, 1923.

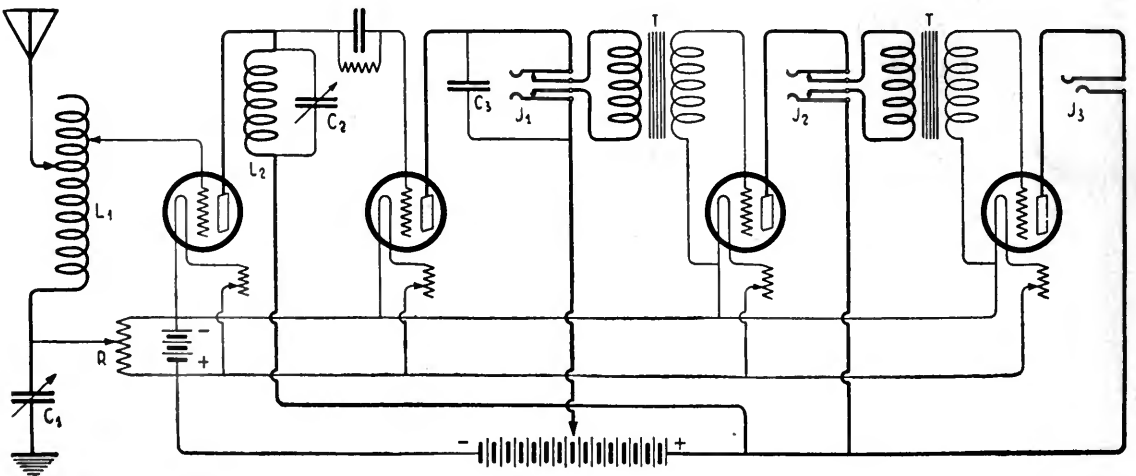

FIG. 2



Magnavox Radio

The Reproducer Supreme

SO simple in operation that any Radio user can obtain perfect results—so sensitive and flexible in scope that the professional will find it fully responsive to every requirement—the new Magnavox Combination Set A1-R or A2-R brings a degree of radio usefulness and enjoyment never before attained.

Every condition in the art of radio reproduction is most successfully met by Magnavox apparatus.

Magnavox Reproducers

- R2 with 18-inch curvex horn . \$60.00
- R3 with 14-inch curvex horn . 35.00
- M1 with 14-inch curvex horn.
Equipped with binding posts
and a five foot flexible cord;
requires no battery for the field. 35.00

Magnavox Combination Sets

- A1-R consisting of electro-dynamic Reproducer with 14-inch curvex horn and 1 stage of amplification 59.00
- A2-R consisting of electro-dynamic Reproducer with 14-inch curvex horn and 2 stages of amplification 85.00

Magnavox Power Amplifiers

- A1—new 1-stage Power Amplifier 27.50
- AC-2-C—2-stage Power Amplifier 55.00
- AC-3-C—3-stage Power Amplifier 75.00

Magnavox Radio Products can be had of good dealers everywhere.
32-page catalog sent on request.

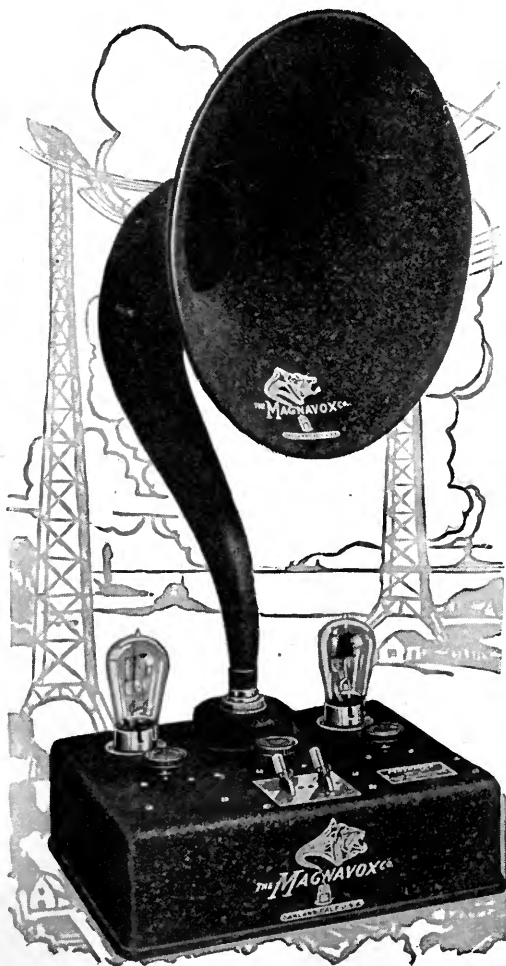

The New Magnavox Combination Sets A2-R [2-stage] and A1-R [1-stage] insure the utmost in convenient, home radio reproduction:

THE MAGNAVOX CO., Oakland, Cal.

New York Office: 370 Seventh Ave.

PERKINS ELECTRIC CO., LTD., MONTREAL, CANADIAN DISTRIBUTORS

New Equipment



**THE MANHATTAN
LOUD SPEAKER**

This is an instrument of fine quality, comparatively free from distortion. In the base of the horn is a concert modulator which regulates the volume to suit the requirements of the room where it is being operated.—Manhattan Electrical Supply Co., Inc., 17 Park Place, New York City. Price \$25

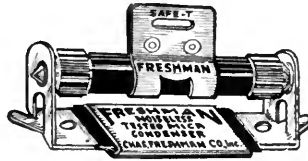

THE FRESHMAN "FIX-O"

A combination of grid condenser and leak with mounting. The plates of the condenser form the support for the leak, which is of standard cartridge size, fitted with the Safe-T handle. The complete unit may be attached without solder.—The Chas. Freshman Co., Inc., 106 Seventh Ave., New York City

THE "IMPROVED" BATTERY SWITCH

A neatly designed unit for connecting or disconnecting the filament battery.—Radio Improvement Co., 25 West 43rd St., New York City

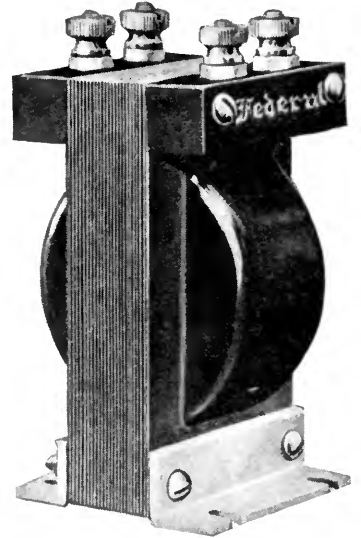
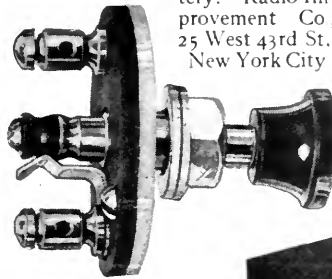

**FEDERAL NO. 65 TRANS-
FORMER**

An audio-frequency transformer of good construction. The lower tones received special consideration in the design of this unit.—Federal Telephone & Telegraph Co., Buffalo, N. Y.



THE CROSLY MULTISTAT

A well designed rheostat for use with all of the vacuum tubes now in common use. Its total resistance is in excess of 20 ohms.—Crosley Mfg. Co., Cincinnati, Ohio. 85 cents



THE HANDY CHARGER

A convenient device for charging storage batteries from the lamp socket. It will fully charge the ordinary six-volt battery in from eight to twelve hours. Will also charge from one to four B batteries at a time.—Interstate Electric Co., St. Louis, Mo.

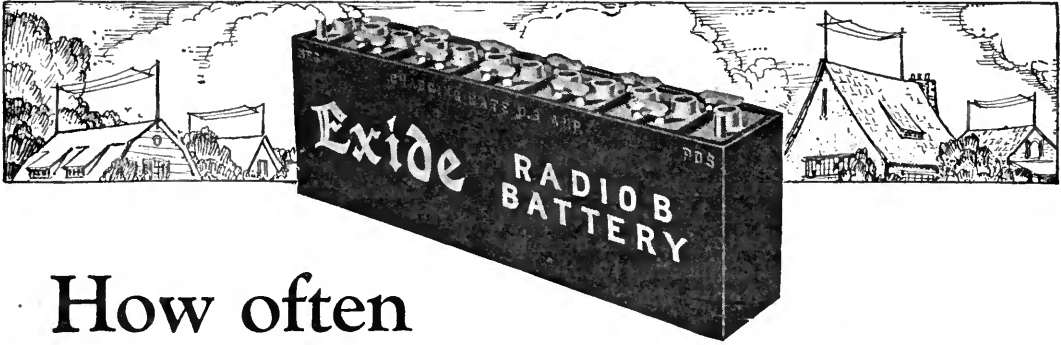

How often do you get a new B battery?

THE current from a B battery is relatively small. But it must be always on the job. B batteries that run down quickly are the bane of the radio fan's existence. Your B battery can help you get the most pleasure from radio, or it can be your greatest nuisance. It all depends on the kind of battery you buy.

The wise radio amateur knows it pays to get a good B battery in the first place. And that means an Exide. The new Exide B Battery is built with extra-heavy plates. That is one reason why it lasts so much longer than the ordinary battery. It can be recharged again and again, saving you the annoyance of frequent replacements.

Exide B Batteries give steady, noiseless current. They are strangers to the hissing, frying noises caused by internal discharge. The 12 cells are encased in rubber, with special vents to allow gas to escape when the battery is being recharged. They are designed throughout to prevent electrical leakage.



Exide A Battery for six-volt tubes

Supplies uniform filament current. Is dependable and long-lasting. Comes in four sizes, of 25, 50, 100 and 150 amp. hr. capacities.

Two low-voltage A batteries

If your set operates on low-voltage tubes, it will be worth your while to examine the new Exide two- and four-volt A batteries. They are right in line with the latest developments in radio receiving. The one-cell Exide A Battery will heat the filament of a 1.1 volt .25 ampere tube for 96 hours; the two-cell Exide A Battery will heat the filament of a 3 volt 60 milliamper tube for approximately 200 hours.

They are specially adapted to WD-11 and UV-199 vacuum tubes.

The Exide A Battery for six-volt tubes gives full-powered, care-free service. It requires only occasional recharging. Like all Exide Radio Batteries, it is built of the finest materials available, is sturdy and long-lasting.

When you hook up your set with Exide A and B Batteries, you are sure of getting maximum signal strength. You can reproduce broadcast selections in clear bell-like tones.

Wherever reliable storage batteries are required, you will find the Exide doing its work ungrudgingly. It is recognized as the leading storage battery in every field of industry. A majority of all government and commercial wireless plants are equipped with Exide Batteries.

Don't let inefficient batteries spoil your pleasure in radio. Go to any radio dealer or Exide Service Station and ask for Exide Radio Batteries.

If your dealer can't supply you with free booklets describing the complete Exide line, write direct to us.

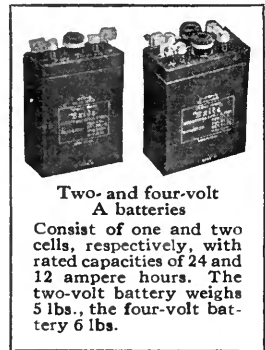

Two- and four-volt A batteries

Consist of one and two cells, respectively, with rated capacities of 24 and 12 ampere hours. The two-volt battery weighs 5 lbs., the four-volt battery 6 lbs.

Exide[★]

RADIO BATTERIES

THE ELECTRIC STORAGE BATTERY COMPANY, PHILADELPHIA

Oldest and largest manufacturers in the world of storage batteries for every purpose

Service Stations Everywhere

Branches in Seventeen Cities

★ Tested and approved by RADIO BROADCAST ★

AMONG OUR AUTHORS

PROFESSOR J. H. MORECROFT ("J.H.M."), who writes our "March of Radio", is continuing his courses this fall at Columbia University. He has been instructor in electrical engineering for the last seventeen years and says that he expects



KENNETH HARKNESS
He rolls up his sleeves and plunges into a detailed description of how to build an excellent one-tube set

to be a teacher the rest of his life, as "contact with young enthusiastic men is wonderfully attractive." During the War, he was engaged by the Navy as scientific expert to develop special forms of submarine detectors.

KENNETH HARKNESS, Chief Engineer of the Radio Guild, New York, has been engaged in the manufacture of

radio equipment for a number of years. He is author of a monograph on "The Construction and Operation of Super-Regenerative Receivers" and has recently had a book published—"Radio-Frequency Amplification."

C. H. HUNTLEY, formerly in newspaper work, joined the G. E. Company several years ago as a special writer, and has done a number of interesting popular magazine articles on electricity and its uses. He has also been known to write verse.



C. H. HUNTLEY
He reveals to us some of the tricks of the drama - broadcasting game as it is played at WGY

IT WAS not until 1919 that Alfred M. Caddell took up writing as a profession. Before that time, he had been, successively, "newsboy, farm hand, railroad man, ranch-owner, traction engineer, airplane mechanic, inventor, and lover of the great outdoors." At Stony Brook, L. I., he is at present "busy turning a piece of woodland into an attractive home place," and building a hydro-airplane to be propelled by a 16-h. p. motor-cycle engine.



W. L. ECKHARDT
The musical trade, he believes, will prove to be the logical organization to sell the complete radio receivers of the near future. However,—

which is at once his business and his hobby.

CARL DREHER has recently been put in entire charge of the Radio Corporation's "Broadcast Central" in New York. His instruc-

—**GEORGE ELTZ**
Doesn't agree with Mr. Eckhardt. He explains in detail why he thinks the electrical dealer is, and will continue to be, the proper and principal outlet for radio. Mr. Eltz has an article on the super-heterodyne also in this issue. He is here shown hurrying home to his "super"—and supper





*Radiotron
UV-199*

For detection or
amplification

\$6.50



*This symbol
of quality
is your pro-
tection*



Radiotron UV-199

A Small Tube That's a Big Performer

The new UV-199 is proving a mighty popular member of the Radiotron family, particularly for portable sets.

Only three-and-a-half inches high. And drawing so small an amperage that it will work on flashlight batteries. It has been called the "tube with nine lives." Battery economy, long life and sensitivity are the big points of Radiotron UV-199. And if by accident it should be operated at too high a temperature, instead of burning out like other tubes, it becomes inoperative and can be brought back to normal operation all over again by disconnecting the "B" battery and lighting the filament for twenty minutes.

For quiet operation—great ruggedness—uniform operation Radiotron UV-199 is unsurpassed. Each new Radiotron has marked a big step in radio advancement. The RCA mark is the foundation of radio growth—and your protection when you buy. Ask for Radiotrons—and look for the mark.

Radio Corporation of America

Sales Dept., Suite 2066: 233 Broadway, New York

District Sales Offices:

10 South LaSalle St., Chicago, Ill.

433 California St., San Francisco, Cal.



Radiotrons

★ Tested and approved by RADIO BROADCAST ★

Digitized by Microsoft®

tive and entertaining articles, "What Goes on at a Transatlantic Station" and "Making Radio Your Business" will be remembered by those who read the April and July, 1923, issues of this magazine.

WALTER L. ECKHARDT, President of the General Radio Corporation, has been prominently identified with the talking machine industry for the last thirty years.

GEORGE J. ELTZ, JR., Radio Sales Manager of the Manhattan Electrical Supply Co., has been a radio amateur and experimenter since 1904. He is a charter member and past President of the Radio Club of America. In 1914, he worked with the Research Department of the W. E. Co. on the first transatlantic telephone tests. During the War, he was a naval aviator, engaged in radio development on airplanes, here and abroad. Motor-

ing, sailing, golf, and hunting are the recreations that appeal to him particularly.

FRANKLIN CLEMENT, of Albert Lea, Minn., is instructor in mathematics at St. Olaf's College (Northfield, Minn.), the institution whose experiences in broadcasting he describes in this issue.

A. J. HAYNES, Vice-President of the Haynes-Griffin Radio Service, has been in the radio game since 1910, first as amateur and later as manufacturer. He left Yale University, where he was a student, in 1917, to enlist in the Naval Reserve, and after serving as operator aboard a destroyer, was sent back to Yale again as radio instructor. The September, 1923, issue of R. B. contains an article about Mr. Haynes—"A Little Foresight and a Big Success," by Alfred M. Caddell.



"HERE IS THE SUGAR WE OWE YOU, AND MA SAYS CAN SHE BORROW YOUR HEAD PHONES AND B BATTERY. WE'RE GONA HAVE COMP'NY TONIGHT"

Among Other Things, Next Month—

We Have in Store for You:

"What Receiver Shall I Buy?," an article by the Editor, helping those who want some kind of radio set but don't know just which, to answer this often perplexing question;

The new Radio Club of America paper: subject, Loud Speakers; author, A. Nyman;

"Various Circuits and What They Mean," by Zeb Bouck. This will be an article for the newcomer to the radio game, the first of a series which will take up, subsequently, the more complex circuits in common use today;

Complete instructions, with photos, circuit diagrams, and working drawings, for the building of a two-stage audio-frequency amplifier, with automatic (jack) filament control, for use with any receiver. This by Carl Goudy.

A tale of real radio adventure—no fiction about it, either;

AND—among the last but not among the least—a revised list of all active broadcasting stations in the United States and Canada. (What's that? Yes, with their wavelengths and kilocycles.)